

Agilent 83453A
High Resolution Spectrometer
User's Guide

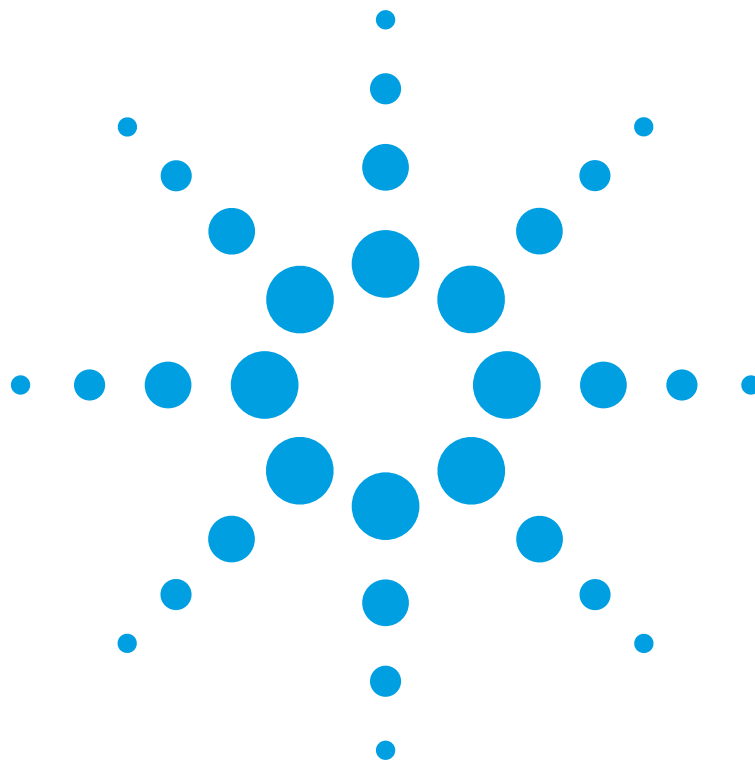

Agilent Technologies

© Copyright
Agilent Technologies 2000
All Rights Reserved. Repro-
duction, adaptation, or trans-
lation without prior written
permission is prohibited,
except as allowed under copy-
right laws.

Agilent Part No. 83453-90001
Printed in USA
January 2002

Agilent Technologies
Lightwave Division
3910 Brickway Boulevard,
Santa Rosa, CA 95403, USA

Notice.

The information contained in this document is subject to change without notice. Companies, names, and data used in examples herein are fictitious unless otherwise noted. Agilent Technologies makes no warranty of any kind with regard to this material, including but not limited to, the implied warranties of merchantability and fitness for a particular purpose. Agilent Technologies shall not be liable for errors contained herein or for incidental or consequential damages in connection with the furnishing, performance, or use of this material.

Restricted Rights Legend.

Use, duplication, or disclosure by the U.S. Government is subject to restrictions as set forth in subparagraph (c) (1) (ii) of the Rights in Technical Data and Computer Software clause at DFARS 252.227-7013 for DOD agencies, and subparagraphs (c) (1) and (c) (2) of the Commercial Computer Software Restricted Rights clause at FAR 52.227-19 for other agencies.

Exclusive Remedies.

The remedies provided herein are buyer's sole and exclusive remedies. Agilent Technologies shall not be liable for any direct, indirect, special, incidental, or consequential damages, whether based on contract, tort, or any other legal theory.

Safety Symbols. CAUTION

The *caution* sign denotes a hazard. It calls attention to a procedure which, if not correctly performed or adhered to, could result in damage to or destruction of the product. Do not proceed beyond a caution sign until the indicated conditions are fully understood and met.

WARNING

The *warning* sign denotes a hazard. It calls attention to a procedure which, if not correctly performed or adhered to, could result in injury or loss of life. Do not proceed beyond a warning sign until the indicated conditions are fully understood and met.



The instruction manual symbol. The product is marked with this warning symbol when it is necessary for the user to refer to the instructions in the manual.



The laser radiation symbol. This warning symbol is marked on products which have a laser output.



The AC symbol is used to indicate the required nature of the line module input power.



The ON symbols are used to mark the positions of the instrument power line switch.



The OFF symbols are used to mark the positions of the instrument power line switch.



The CE mark is a registered trademark of the European Community.



The CSA mark is a registered trademark of the Canadian Standards Association.



The C-Tick mark is a registered trademark of the Australian Spectrum Management Agency.

ISM1-A

This text denotes the instrument is an Industrial Scientific and Medical Group 1 Class A product.

Typographical Conventions.

The following conventions are used in this book:

Key type for keys or text located on the keyboard or instrument.

Softkey type for key names that are displayed on the instrument's screen.

Display type for words or characters displayed on the computer's screen or instrument's display.

User type for words or characters that you type or enter.

Emphasis type for words or characters that emphasize some point or that are used as place holders for text that you type.

General Safety Considerations

This product has been designed and tested in accordance with the standards listed on the Manufacturer's Declaration of Conformity, and has been supplied in a safe condition. The documentation contains information and warnings that must be followed by the user to ensure safe operation and to maintain the product in a safe condition.

Install the instrument according to the enclosure protection provided. This instrument does not protect against the ingress of water. This instrument protects against finger access to hazardous parts within the enclosure.

WARNING **If this product is not used as specified, the protection provided by the equipment could be impaired. This product must be used in a normal condition (in which all means for protection are intact) only.**

WARNING **No operator serviceable parts inside. Refer servicing to qualified service personnel. To prevent electrical shock do not remove covers.**

WARNING **This is a Safety Class 1 Product (provided with a protective earthing ground incorporated in the power cord). The mains plug shall only be inserted in a socket outlet provided with a protective earth contact. Any interruption of the protective conductor inside or outside of the instrument is likely to make the instrument dangerous. Intentional interruption is prohibited.**

WARNING **To prevent electrical shock, disconnect the instrument from mains before cleaning. Use a dry cloth or one slightly dampened with water to clean the external case parts. Do not attempt to clean internally.**

WARNING **For continued protection against fire hazard, replace line fuse only with same type and ratings (type nA/nV). The use of other fuses or materials is prohibited.**

CAUTION Fiber-optic connectors are easily damaged when connected to dirty or damaged cables and accessories. The Agilent 83453A's front-panel input connector is no exception. When you use improper cleaning and handling techniques, you risk expensive instrument repairs, damaged cables, and

General Safety Considerations

compromised measurements. Before you connect any fiber-optic cable to the Agilent 83453A, refer to [“Cleaning Connections for Accurate Measurements”](#) on page 6-16.

CAUTION

This product is designed for use in Installation Category II and Pollution Degree 2 per IEC 61010-1C and 664 respectively.

CAUTION

Always use the three-prong ac power cord supplied with this instrument. Failure to ensure adequate earth grounding by not using this cord may cause instrument damage.

CAUTION

This instrument has autoranging line voltage input. Be sure the supply voltage is within the specified range.

CAUTION

Use of controls or adjustment or performance of procedures other than those specified herein may result in hazardous radiation exposure.

1 Installation

Installation 1-2

Step 1. Prepare the Site 1-3

Step 2. Install the Monitor Mount Assembly 1-6

Step 3: Install the Monitor, Keyboard and Mouse 1-7

Step 4. Install the Work Surface 1-9

Step 5. Confirm Front and Rear Panel Connections 1-10

Step 6. Turn the System On 1-12

Laser Safety Considerations 1-13

Basic Performance Verification 1-14

2 Getting Started

Introduction 2-2

Software Overview 2-4

Quick Tour 2-5

3 Using the HRS

Theory of Operation 3-2

Tunable Laser Measurements 3-13

Transmitter Measurements 3-23

4 Function Reference

Function Reference 4-2

File Menu 4-3

View Menu 4-10

Setup Menu 4-29

Measure Menu 4-39

System Menu 4-41

Application Toolbar 4-43

Measurement Results Area 4-52

5 Remote Programming

Overview 5-2

HRS Remote Control DLL 5-3

Using the HRS Remote Control 5-10

HRS Example 5-11

Contents

6 Maintenance

Troubleshooting the HRS System 6-2

Software Upgrade Procedure 6-12

Hard Drive Backup and Recovery 6-14

Cleaning Connections for Accurate Measurements 6-16

Returning the Instrument for Service 6-26

Agilent Technologies Service Offices 6-28

7 Specifications and Regulatory Information

Definition of Terms 7-3

Specifications 7-5

Frequency Specifications 7-6

Amplitude Specifications 7-7

General Instrument Specifications 7-8

Regulatory Information 7-9

Declaration of Conformity 7-10

Installation 1-2
Agilent 83453A Cabling Configuration 1-11
Laser Safety Considerations 1-13
Basic Performance Verification 1-14

Installation

Installation

The instructions in this chapter show you how to install the 86453A HRS system. For overseas sales, the product is shipped *without* an ac power connector. You should have a local electrician provide and install an ac connector that meets the standards for the region. Also, be sure to set all instruments to use the local line voltage.

Tools needed:

- Utility knife
- 1/8" Allen wrench
- 7/32" Allen wrench
- T-25 Torx driver
- 9/16" wrench

Step 1. Prepare the Site

Your site should accommodate the dimensions, weights, and power consumption limits shown in the following figure.

WARNING

This system weighs approximately 600 lbs (270 kg). To avoid injuries, use proper moving equipment and use extreme care when installing.

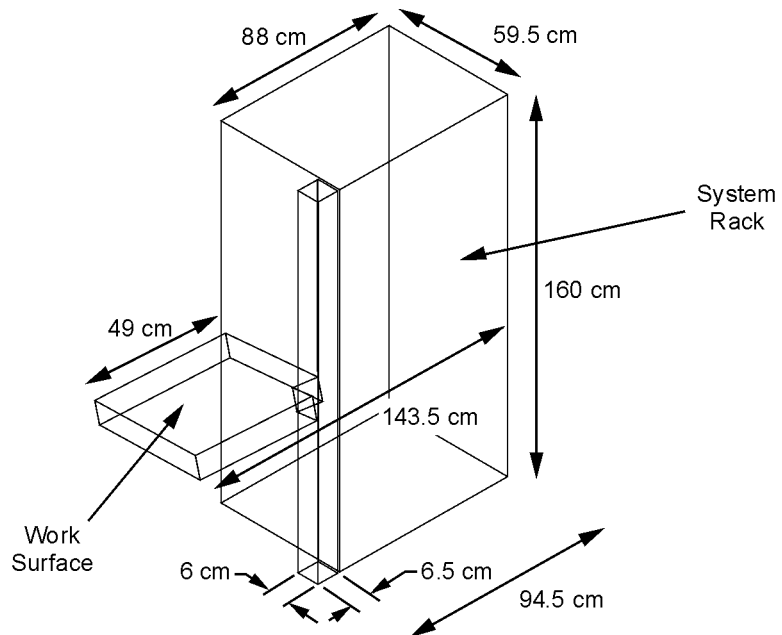

Figure 1-1. Rack dimensions

Step 1. Prepare the Site

WARNING

Install the system so that the power cords are readily identifiable and are easily reached by the operator. The power cords are the disconnecting device. They disconnect the mains circuits from the mains supply before other parts of the system. Alternately, an externally installed switch or circuit breaker (which is readily identifiable and is easily reached by the operator) may be used as a disconnecting device.

CAUTION

Always use the three-prong ac power cord supplied with this instrument. Failure to ensure adequate earth grounding by not using this cord may cause instrument damage.

CAUTION

This instrument has autoranging line voltage input. Be sure the supply voltage is within the specified range.

CAUTION

Install the system according to the enclosure protection provided. This system does not protect against the ingress of water. The system protects against finger access to hazardous parts within the enclosure.

CAUTION

The stem rack LINE switch disconnects the mains circuits from the mains supply.

Table 1-1. General Site Requirements

Operating temperature	23°C ±3° C
Power Requirements	20 amp block with 2 power outlets
LAN ports	Standard system: 1

Step 2. Install the Monitor Mount Assembly

Refer to [Figure 1-2 on page 1-8](#) for the following procedure.

NOTE

A monitor mount extrusion has been installed on both the left and right sides of the system rack. This allows you to attach the monitor to either side of the system rack.

- 1 Remove the black end cap from the top of the extrusion.
- 2 Slide the star knob onto the lower part of the extrusion and tighten.
- 3 Loosen the two black levers on the friction plate and slide it onto the extrusion.
- 4 Move the friction plate to the desired height and tighten the two black levers.
- 5 Loosen the star knob and raise it until it stops below the friction plate, then tighten the knob securely to prevent the friction plate, arm, and monitor mount assembly from falling.

WARNING

If the star knob is not installed properly, the friction plate, arm, and monitor mount assembly may fall, causing injury to the user or damage to the monitor and mounting components.

- 6 Attach the keyboard tray to the monitor mount assembly using the six provided mounting screws. Tighten with a 1/8" Allen wrench.

CAUTION

Tighten all hardware on the arm and monitor mount assembly as necessary to prevent the monitor and keyboard from tipping unexpectedly.

CAUTION

Be careful when swinging the arm around in front of the system to avoid striking the system components.

- 7 Replace the black end cap on the extrusion.

Step 3: Install the Monitor, Keyboard and Mouse

- 1** Attach the LCD monitor to the monitor mount assembly with the provided mounting screw. Tighten with a 7/32" Allen wrench. Make sure the monitor is properly oriented with the alignment pin, then tighten with a 7/32" Allen wrench. Refer to [Figure 1-2 on page 1-8](#).
- 2** Connect the monitor cables from the power module to the monitor. The power module is attached to the tray located just below the work surface area. Refer to [Figure 1-3 on page 1-11](#).

Tip: It is easier to connect the cables by first removing the monitor mount bracket from the monitor.

- 3** Place the keyboard on keyboard tray. Route the cable from the keyboard through the hole on the tray.
- 4** Connect the keyboard cable to the keyboard extension cable. The cable is attached to the tray located just below the work surface area.
- 5** Secure the monitor and keyboard cables to the bottom of the arm using tie wraps. Be sure to allow for free movement in all directions.
- 6** Route the mouse cable below the space for the work surface and connect it to the rear panel of the system controller.
- 7** Use the cable clamps on the bottom of the work surface to secure the mouse cable.

Step 3: Install the Monitor, Keyboard and Mouse

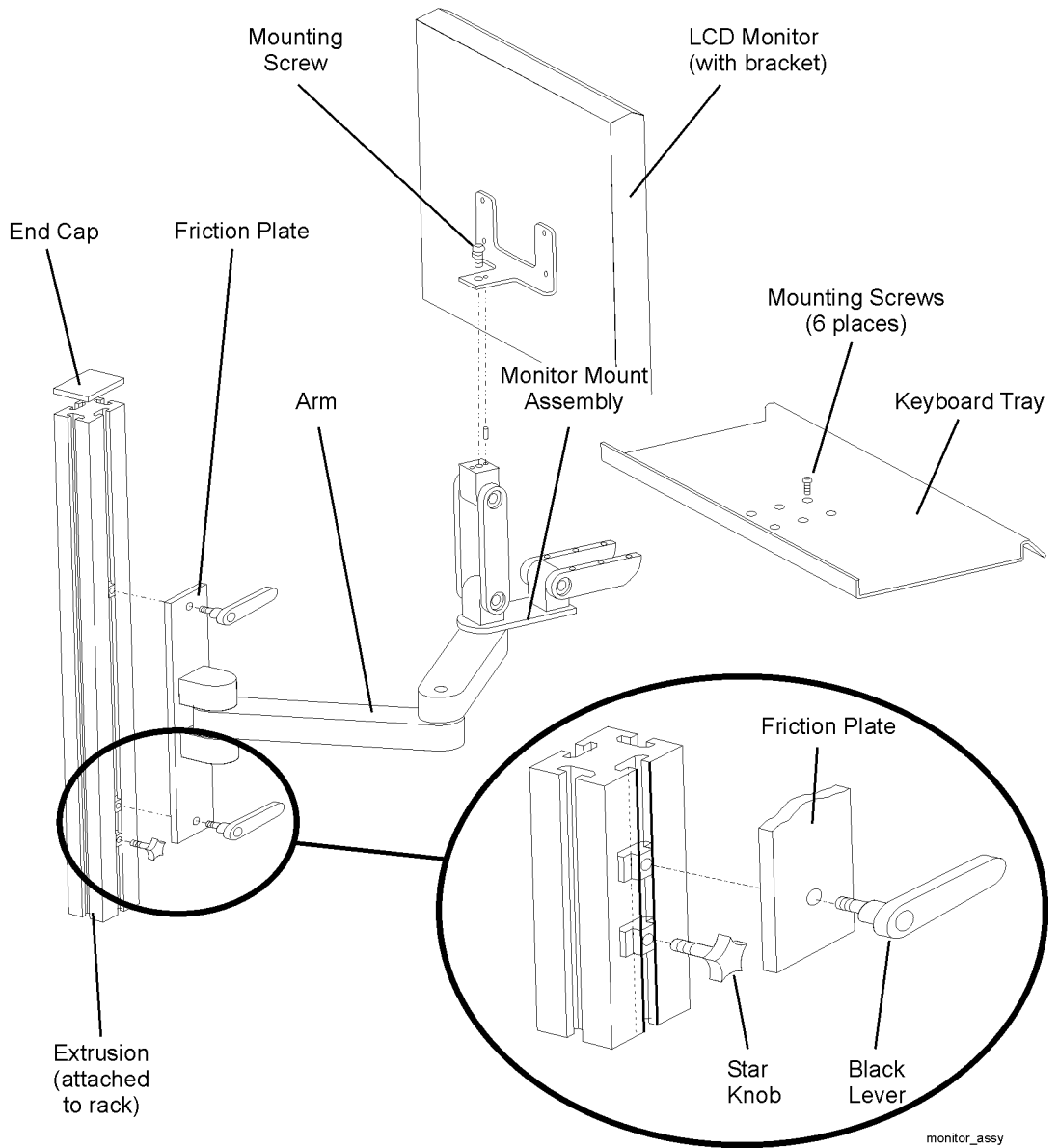

Figure 1-2. Monitor Mount Assembly

Step 4. Install the Work Surface

NOTE

Make sure that the monitor cables are connected to the power module before installing the work surface.

- 1 Slide the rails into the rack and lock the pins at the front. Attach the rails to the rear of the rack using a T-25 Torx driver and the hardware already installed on the back of the rack.
- 2 Slide the work surface over the rails and secure it using the hardware provided.

CAUTION

When sliding in the work surface, be careful to not damage the cables that are going to the monitor, keyboard, and mouse.

Step 5. Confirm Front and Rear Panel Connections

Step 5. Confirm Front and Rear Panel Connections

NOTE

Breaking an optical connection inside of the system may require recalibrating the system by an Agilent Service Engineer.

You must clean the connectors every time an optical cable is connected. Refer to [“Cleaning Connections for Accurate Measurements”](#) on page 6-16.

- 1 Confirm the cabling of the Agilent 83453C HRS system. Refer to [Figure 1-3](#) on page 1-11 and the table below.

Table 1-2. BNC cables from the System Controller to the Coherent Receiver

System Controller Rear Panel	Coherent Receiver Rear Panel
PC MA+	MA+
PC MA-	MA-
PC MB+	MB+
PC MB-	PB-
PC SA+	SA+
PC SA-	SA-
PC SB+	SB+
PC SB-	SB-

Step 5. Confirm Front and Rear Panel Connections

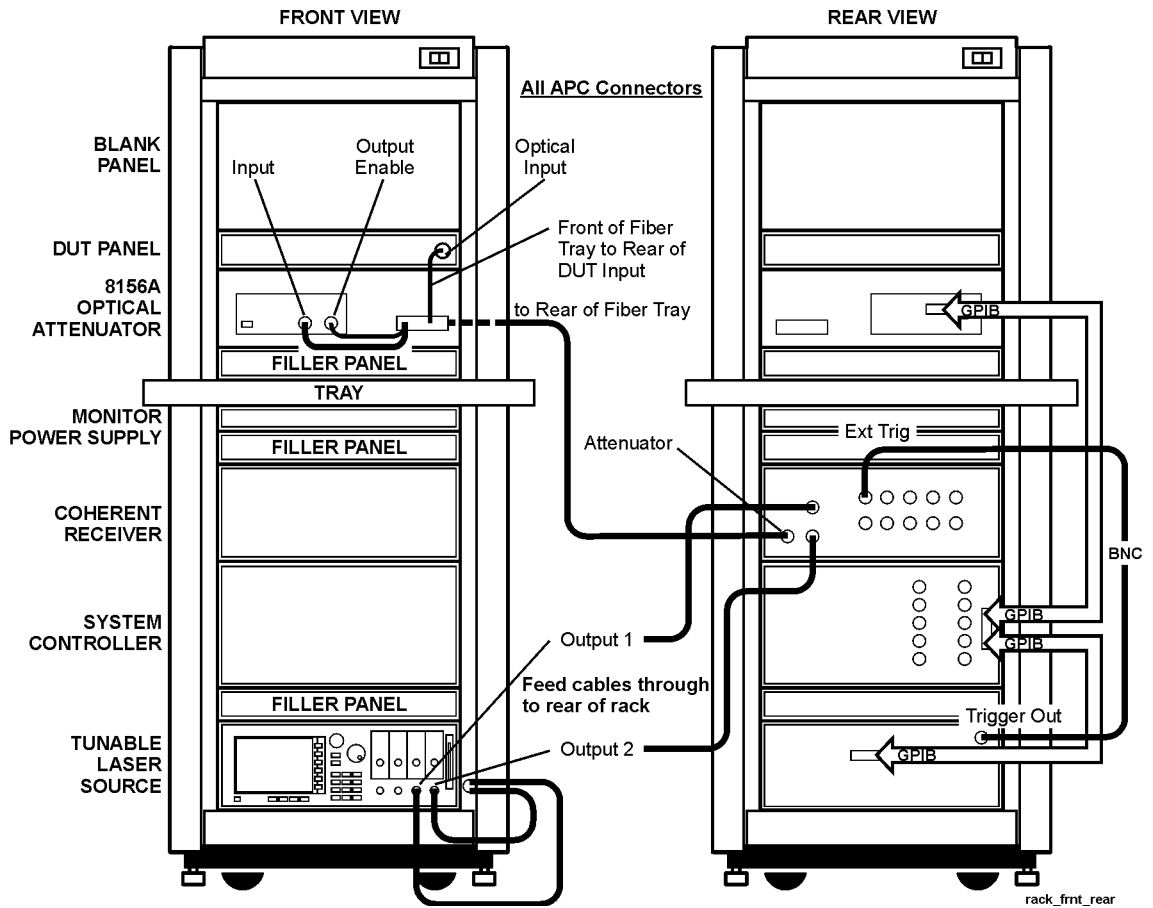

Figure 1-3. Agilent 83453A Cabling Configuration

rack_frnt_rear

Step 6. Turn the System On

CAUTION

Agilent Technologies does not recommend installing any additional software on the system controller. Some third party software, including printer drivers, may impair operation.

CAUTION

This product is designed to work with MS Windows 2000®. Changing to another MS Windows operating system or a localized version of MS Windows 2000® voids the HRS system warranty.

- 1 Plug in the Power Distribution Units (PDU).
- 2 Turn on the rack main power switch, and then turn on the power switches for each of the individual system components. It is recommended that you use the main power switch for emergency power shut off only. Always turn the power to the system components on or off individually.
- 3 Allow the system to warm up for two hours.
- 4 Perform a system verification. [Refer to “Basic Performance Verification” on page 1-14.](#)

NOTE

Networking may vary from company to company. Please contact your local IT department or network administrator for assistance with connecting the 83453A to your Local Area Network. For additional assistance, consult the MS Windows 2000® online help under Networking.

Laser Safety Considerations

NOTE

Refer to the *Tunable Laser Modules User's Guide* for complete laser safety information.

Laser Safety

Laser radiation in the ultraviolet and far infrared parts of the spectrum can cause damage primarily to the cornea and lens of the eye. Laser radiation in the visible and near infrared regions of the spectrum can cause damage to the retina of the eye.

WARNING

Do NOT, under any circumstances, look into the optical output or any fiber/device attached to the TLS output while the laser is in operation.

This system should be serviced only by authorized personnel.

Do not enable the laser unless fiber or an equivalent device is attached to the optical output connector.

CAUTION

Use of controls or adjustments or performance of procedures other than those specified herein can result in hazardous radiation exposure.

Electrical Safety

The electrical safety considerations are documented in the section "[General Safety Considerations](#)" on page -iii. Familiarize yourself with the safety markings and instructions before operating this system.

Basic Performance Verification

Required Equipment:

- 8164A Lightwave Mainframe
- 81634A Power Sensor Module
- 81640A Tunable Source
- Agilent Multi-wavelength Meter

Required Accessories

- New 9um APC Patchcord
 - Pure Isopropyl Alcohol
 - Lint Free Cotton Swabs
 - Condensed Air
- 1** Turn on the HRS. On shipment, the HRS PC controller has the administrator account configured with no password. Login the first time using the “administrator” account. When you are logged in as an administrator you are able to set up individual user accounts.
 - 2** Align the touch screen display, if needed.
 - a** Using the mouse, click Start > Settings > Control Panel > ELO Touchscreen.
 - b** From the ELO Touchscreen Properties, click the General tab and then Align.
 - c** Following the on screen prompts to align the cursor with your finger touch.
 - 3** Using a new 9 μm angled patchcord, connect a clean, unmodulated, TLS signal at -15 dBm, 1550 nm to the HRS Optical Input connector.

IMPORTANT

Before connecting any patchcords, you must clean the optical connections on the instrument and on the cable. Use cotton swabs and alcohol to clean the connectors, and then blow the connector surface dry with compressed air. For more information, refer to [“Cleaning Connections for Accurate Measurements”](#) on page 6-16.

- 4 Ensure that Noise Suppression is enabled in the Auto Measure Setup Panel. From the main menu, click Setup > Auto Measure Setup > select the Noise Suppression > Close

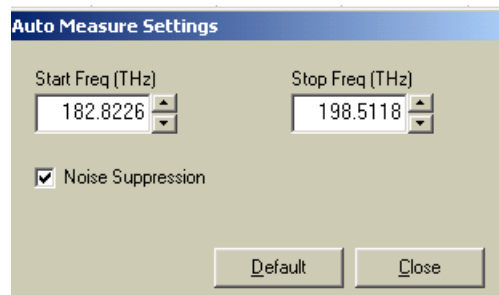

Figure 1-4. Auto Measure Settings Dialog

- 5 On the toolbar, click Auto Measure. The HRS will locate and zoom in on the input signal.

Installation

Basic Performance Verification

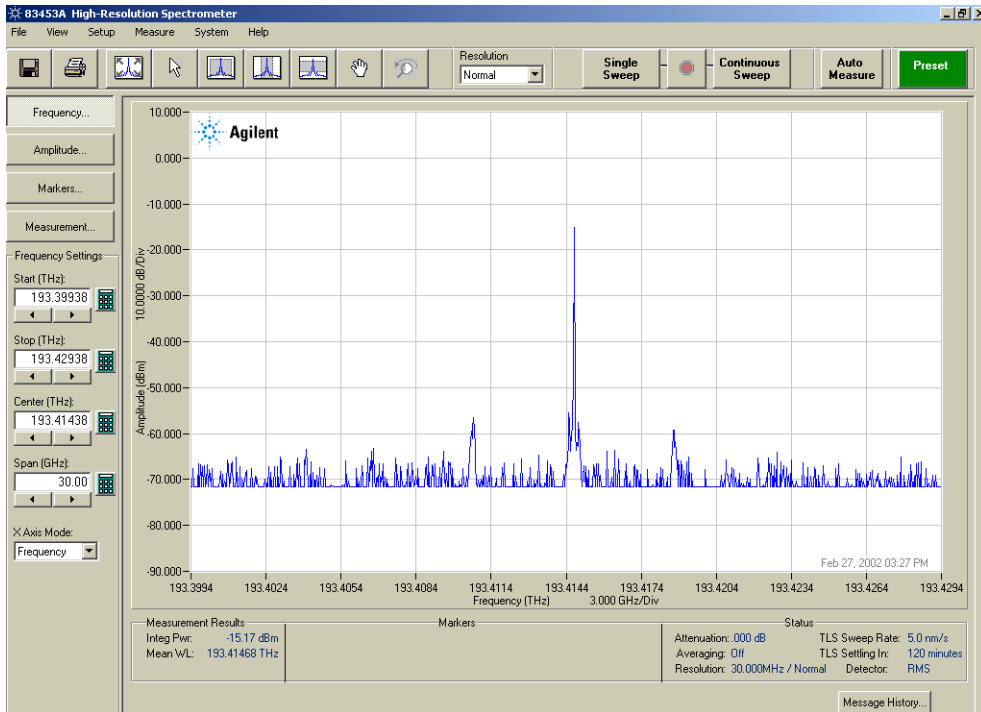

Figure 1-5. Results of the Auto Measure

- From the Setup panel, click Frequency > Span, and adjust the span to 10 GHz. This will set the system TLS sweep rate (displayed in the status area in the lower right hand corner of the display) to 1 nm/s, which will provide maximum measurement accuracy.

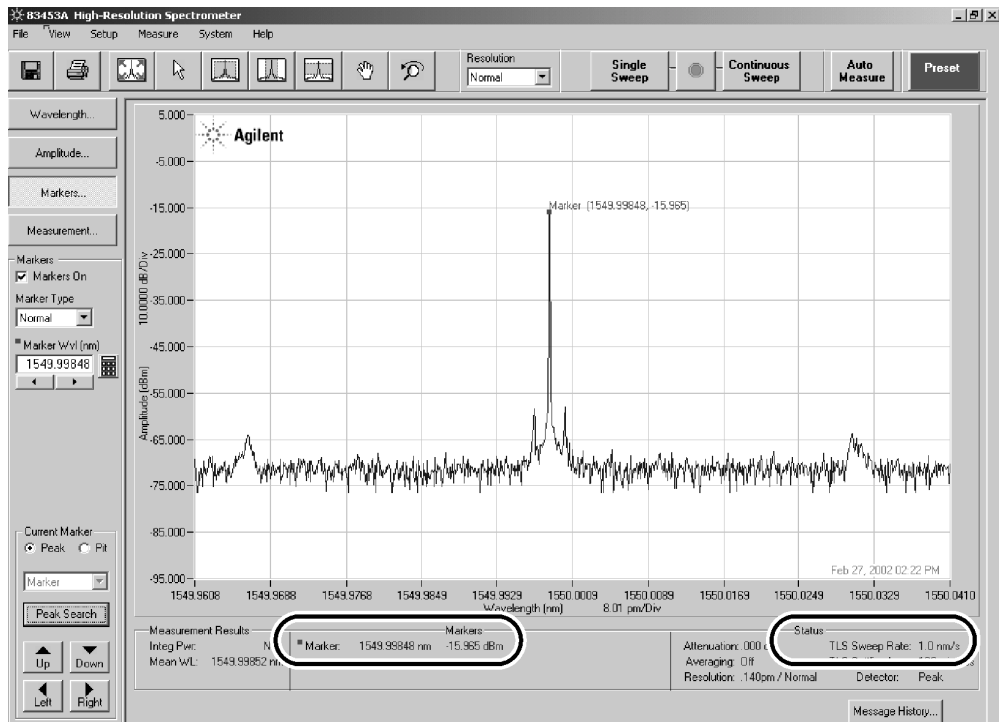

Figure 1-6. Location of Marker Results and TLS Sweep Rate

- 7 From the Setup panel, click Amplitude > Peak detection.
- 8 From the Setup panel, click Frequency > X-axis Mode and select Wavelength to display wavelength units along the horizontal axis.
- 9 From the Setup panel, click Markers > Markers On > Marker Type Normal > Peak Search to place a marker at the highest peak.

Basic Performance Verification

- 10 The marker wavelength and amplitude values will be displayed in the Marker area located at the bottom of the display. Record the signal's wavelength and power in [Table 1-3](#).
- 11 From the toolbar, click Single Sweep. Observe the signal's sweep-to-sweep variation. Record the peak amplitude, and the wavelength of the peak signal over the next fourteen sweeps.

Table 1-3. Sweep-to-Sweep Wavelength and Amplitude Variation

Sweeps	Wavelength	Peak Amplitude
1		
2		
3		
4		
5		
6		
7		
8		
9		
10		
11		
12		
13		
14		
15		

- 12 From [Table 1-3](#), find the maximum and minimum wavelength and amplitudes, and calculate the peak-to-peak deviation _____ .

With a stable input signal, the peak to peak variation in power should be less than 1.5 dB (the Amplitude Repeatability Specification), and the variation in wavelength should be less than 1 pm (the Wavelength Repeatability Specification). For complete system specifications, refer to “Specifications and Regulatory Information” on page 7-1.

- 13** Calculate the average peak power for the 15 sweeps you have just taken. Turn off the laser, and move the input signal to a power meter. Turn the laser back on, and set the power sensor wavelength to the wavelength of your input signal.
- 14** Record the signal power as read by the power sensor module _____ .
The difference in the average power measurement made by the HRS and that made by the power sensor module should be less than 6 dB. This takes into account amplitude accuracy, polarization dependent loss, and scale fidelity. By averaging, we have removed repeatability variation.
- 15** Determine the difference between laser wavelength as measured by the HRS, and the known laser wavelength. The difference between measured and actual wavelength should be less than 15 pm. To determine actual wavelength, use a multi-wavelength meter.
- 16** From the Setup panel, click Measurement > Reference Trace > Save.
- 17** Apply 100 kHz modulation to the input source. For the 81640A tunable source, change the modulation source to internal, with a 100 kHz frequency. Observe the signal on the HRS system. There may be a wavelength difference in the two signals due to the laser frequency changing (chirping) under modulation.

Installation

Basic Performance Verification

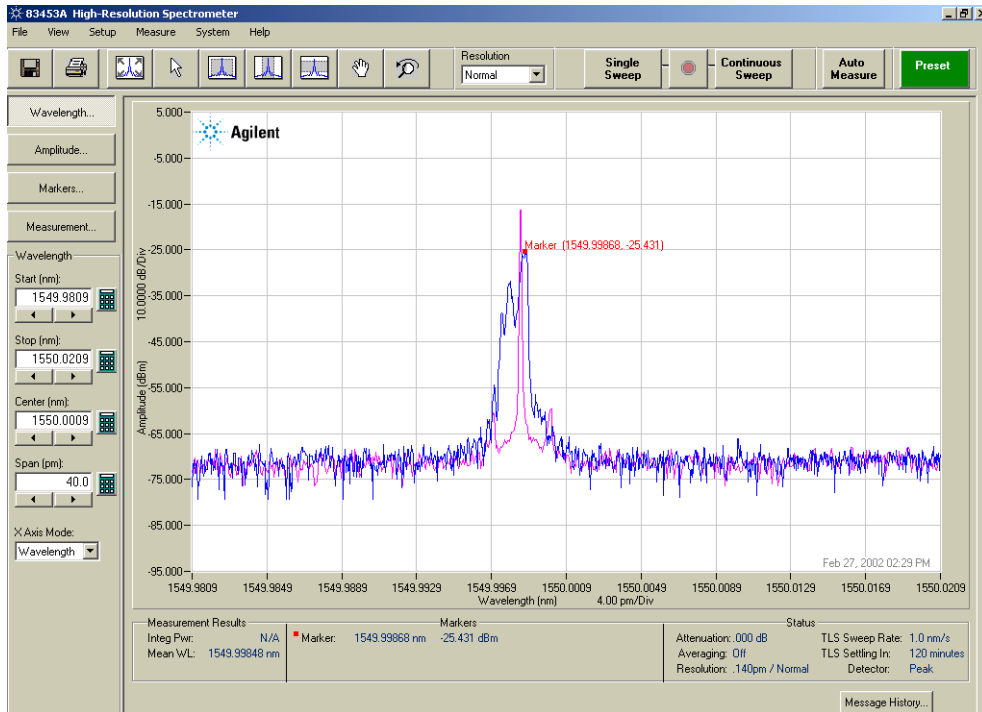

Figure 1-7. Chirping May Occur when Modulation is Applied

- 18 The noise floor of the measured signal may increase as the input signal is modulated, refer to “Chirping May Occur when Modulation is Applied” on page 1-20. Noise Suppression should be rerun with changes to the input signal. From the HRS menu bar, click System > Operations > Noise Suppression. This optimizes the noise floor for the modulated signal. The noise floor of the measured signal should return to near the same value as it was for the unmodulated signal.
- 19 Finally, turn the laser modulation off and take another sweep. Check the noise level 10 GHz (or 80 pm at 1550 nm) from the peak signal. You may need to increase the sweep span. The specified dynamic range is -50 dBm. Ensure that the noise floor at 80 pm offset is at least -50 dBm.

Introduction 2-2
Software Overview 2-4
Quick Tour 2-5

Getting Started

Introduction

The Agilent 83453A high resolution spectrometer (HRS) provides hundreds of times better resolution than conventional grating-based optical spectrum analyzers (OSA). The HRS system allows extremely fine sub-picometer spectral resolution measurements on tunable lasers, transmitters, and systems. Modulation analysis on the optical signal is now possible.

The HRS operates over a 1520 nm to 1620 nm wavelength range with multiple resolution and span settings that allow you to view a variety of spectra. Three resolution settings of high, normal, and wide enable you to trade measurement speed and accuracy with the ability to view fine details. Variable span settings allow you to zoom in on any part of the signal.

With high resolution and dynamic range, the 83453A characterizes tunable lasers and transmitter spectral features such as:

- Modulation and spectral content
- Sub-carrier modulation and separation
- Ultra-dense WDM channel separation, spacing and interaction
- Crosstalk
- Linewidth of modulated and unmodulated sources
- Relaxation oscillation
- Laser spectral symmetry
- Chirp
- Close-in spurious sidebands

The 83453A is a fully calibrated and integrated system based on optical heterodyne techniques. All the components necessary in an optical heterodyne spectrum analyzer are integrated into a 1.3-meter rack. The HRS system includes the following components:

- Agilent E9393A coherent receiver
- Agilent 86140A tunable laser (used as a local oscillator)
- Agilent 8156A variable attenuator
- System controller and software
- Keyboard, mouse, touch screen monitor, and printer

The HRS has a MS Windows® based graphical user interface that is easy to use. All of the measurement controls are available on the touch screen display and are easily accessible. Features such as, wavelength, amplitude, and zooms; point, bandwidth, delta markers, and ITU grid; frequency or wavelength trace display; spectral integration and linewidth; trace averaging and data exporting are built into the HRS.

Software Overview

The HRS user interface is shown below. Note the naming conventions used on the different areas. These names will be used throughout the user's guide to direct you to the location of a particular feature.

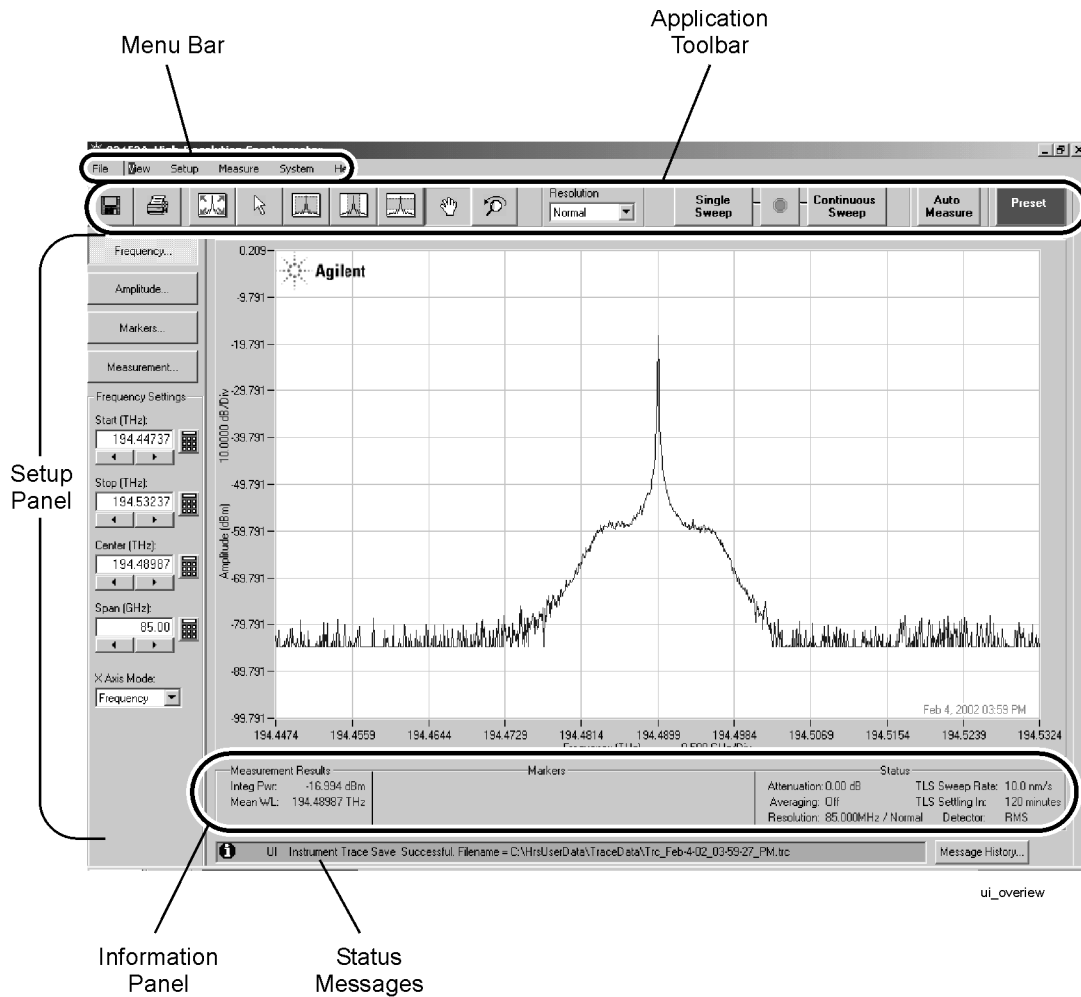

Quick Tour

This tutorial introduces you to the HRS measurement capabilities and user interface features. You will perform an automatic measurement, explore zoom functions, detection methods, and marker search capabilities. After finishing this section, you may want to proceed to [“Using the HRS” on page 3-1](#) and to [“Function Reference” on page 4-1](#) for specific information on each function.

Performing an Auto Measure

For this tutorial, we used a distributed feedback laser (DFB) with 2.5 GHz PRBS modulation.

You can follow along with the tutorial by using any laser in the C or L band. The laser does not need to be modulated; however, certain features of the user’s interface will be demonstrated better with modulation applied.

[Refer to “Software Overview” on page 2-4](#) for assistance with locating the different areas of the user interface. For example, the left side of the display is referred to as the Setup Panel. During the tutorial, you will be asked to make specific selections from the Setup Panel.

1 Check output power of your signal source.

Total average power into the HRS must not exceed +23 dBm, including power from pump lasers. The HRS is optimized for a –5 dBm peak input power to the detectors. An input attenuator is provided to accommodate larger signals. (You can adjust the attenuation level by clicking the Amplitude button on the Setup Panel.)

2 Check the connector type on the signal source.

The HRS comes equipped with an angled FC/PC optical input connector. Agilent supplies other adapters for other connector styles, but an angled connector should be used. A straight connector can be connected to the HRS without risk of damage, but there will be an air gap that attenuates the signal and causes a large reflection back into the signal source, and impairs accuracy of any amplitude measurements.

Quick Tour

- 3 Clean and connect the signal source to the Optical Input of the HRS. Refer to “Cleaning Connections for Accurate Measurements” on page 6-16.

Agilent recommends doing at least a dry wipe with a clean cotton swab each time an already-clean connector is connected and disconnected.

- 4 Click **Preset** on the user interface to return it to a known state. Most of the time this will not be necessary, particularly if the system has just been turned on.
- 5 Click **Auto Measure** on the toolbar. The HRS will take several sweeps as it finds and zooms in on the signal. For more detailed information, refer to “Understanding Auto Measure” on page 2-20.

The figure below shows the result of the Auto Measure on a DFB laser externally modulated at 2.5 Gbit PRBS (2¹⁵, no framing information.) The Auto Measure includes a noise suppression algorithm to optimize sensitivity and noise. This noise suppression can be run at any time. Refer to “Noise Suppression” on page 4-37.]

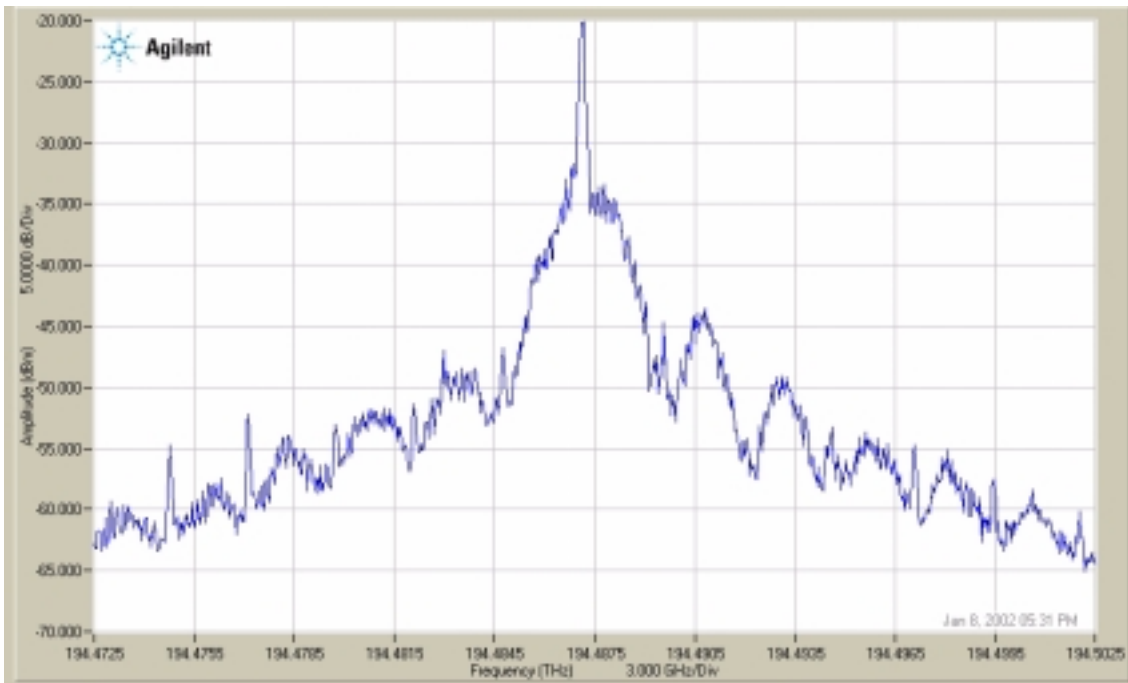

Figure 2-8. Auto Measure Results of a DFB Laser

The measurement above is the equivalent of building an optical filter 15 MHz wide that you could tune to each trace point, and measure the power in that 15 MHz wide spectral slice. The optical filter would maintain a smooth Gaussian shape 60 dB below the pass band.

Another way to think of the measurement is as the magnitude of the Fourier transform of the E-field of the optical waveform. You could imagine using a high speed optical sampling oscilloscope to capture the waveform as a function of time and taking the Fourier transform. An actual sampling oscilloscope would be disappointing because it has neither the amplitude accuracy nor the dynamic range of the HRS. Instead of acquiring data in the time domain, the HRS uses an optical heterodyne receiver to implement a discrete Fourier transform, allowing it to operate directly in the optical frequency domain.

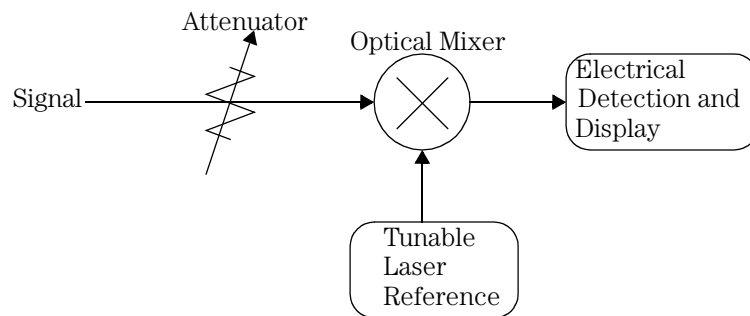

Figure 2-9. Simplified Block Diagram of the HRS

The optical mixer uses a nonlinear effect to generate the difference frequency between the input signal and the tunable laser. An electrical filter selects a 15 MHz portion of this difference spectrum. The filtered power is detected as the tunable laser changes wavelength, effectively projecting the filter into the optical frequency domain as a tunable filter. [Refer to “Theory of Operation” on page 3-2](#) for more detailed information.

Using the Zoom Functions

- 1 From the toolbar, select the Wavelength Zoom cursor  and then click and drag the cursor over an interesting part of the trace to zoom in. Note that this is a temporary zoom until the next sweep, when data is acquired over the new span. You can zoom back out with , `ctrl-z`, or fit to screen .

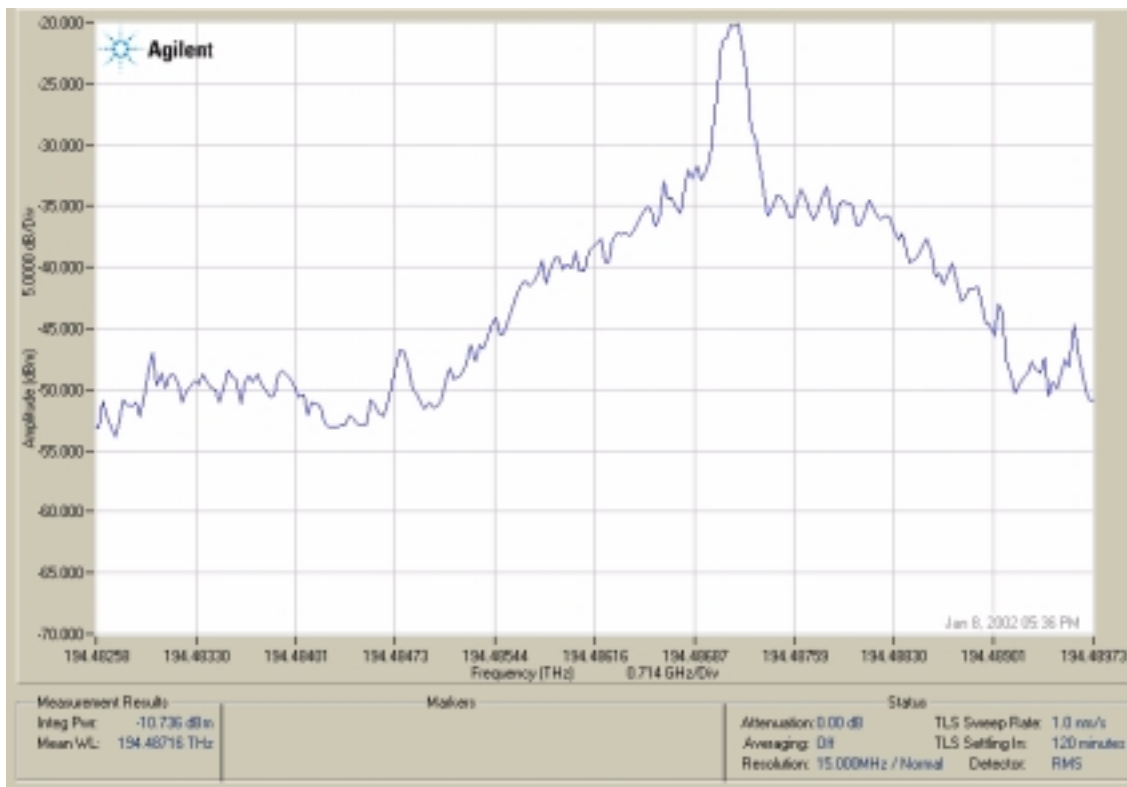



Figure 2-10. Zoomed-in Portion of the Trace

- 2 From the toolbar, select the Pan Display icon  and move the trace around.

The integrated power and mean wavelength calculations in the lower left corner recalculate based on just the displayed portion of the trace, allowing you to analyze specific trace features. The Linewidth and Spectral Width measurements also operate only on the displayed portion of the trace. (Linewidth and Spectral Width selections are accessed by clicking the Measure button on the Setup Panel and then selecting from the Measurement list box.)

When done with the Zoom cursors, click the Object Select icon  to return the cursor to normal operation.

Using the Amplitude Detection Methods

The HRS measures power as a function of wavelength

Turning on the marker displays the power (in dBm) and frequency or wavelength of a trace point. This means that the HRS detected the power at a small slice of the spectrum about the indicated frequency. Note that the HRS is a sweeping instrument that never stops. The instrument acquires RMS (root mean square) power continuously, and that power record is later divided into sub-spans that correspond to each trace point.

Normally, the sub-span is equal to the trace point spacing, so that each trace point (and hence each marker value) corresponds to the amount of power measured between a trace point and its neighboring trace point. Specifically, the HRS synchronizes its detection so that each trace point corresponds to the power measured as the instrument sweeps from the midpoint preceding the current point to the midpoint following.

For example, suppose you have a 1001 point sweep (the default). If you sweep over 100 GHz, each trace point corresponds to:

$$\frac{\text{span}}{\text{tracePoints} - 1}$$

or 100 MHz. If you place a marker at 193.4 THz, the marker will read the power detected as the sweep progressed 100 MHz centered on 193.4 THz. That is, the power detected from 50 MHz below 193.4 THz to 50 MHz above 193.4 THz.

RMS Detection

The HRS has two detection modes: RMS and Peak (accessed from the Amplitude button on the Setup panel). The default is RMS mode, in which the marker reads the RMS power detected as the sweep progresses through the sub-span corresponding to that trace point. The term RMS implies that a true RMS-power responding detector is used. (That is, integrated power over the sub-span.) It does not imply that the average power over the sub-span is reported. Thus, if you configure a sweep so that all the components of a signal are captured, you can calculate the total power by adding the RMS trace points together. This result will coincide with a power meter. This calculation is reported as the Integrated Power in the Measurement Results area located at the bottom of the display.

Since the RMS mode integrates power over the sub-span for a given trace point, the amount of power reported will tend to decrease as the span is decreased. This does not indicate a change in the input signal, it indicates a change in how much spectrum is associated with each trace point.

Peak Detection

The second detection mode is peak detection. Peak detection should be used when there is a coherent signal much narrower than the sub-span associated with a single trace point. In this case, the coherent signal can get washed out by other signals in the sub-span such as broader-band modulation. With the peak detection mode, the HRS determines the power in the largest signal found in the sub-span. The notation can again be confusing because we are still using an RMS responding detector, but instead of integrating the power across a sub-span to get a trace point, we take the peak observed power.

Resolution

The HRS normally configures the sub-span for each trace point to be from the midpoints between the preceding and following trace points. For narrow spans, however, the detection bandwidth is greater than the trace point spacing. The approximate detection bandwidth is indicated in the Status area (lower portion of the display) as `Resolution`. When the detection bandwidth exceeds the spacing between trace points, the detected power in RMS mode is always scaled so that the total power when the trace points are added up is correct.

Tip: To convert power in RMS mode to power spectral density, divide by the trace point spacing $\frac{span}{tracePoints - 1}$.

This value is calculated and displayed in the Status area as `Resolution`. For example, if the HRS is in RMS mode, with a 1001 point trace on a 100 GHz span, the Resolution indicator will display 100 MHz RBW or,

$$\frac{100GHz}{1001 - 1} = 100 \frac{MHz}{point}$$

Thus, if a marker says -10 dBm, the power per Hz is:

$$-10dBm - 10\log 100e6 \frac{Hz}{Point} = -10 - 80 = -90 \frac{dBm}{Hz}$$

This discussion assumes that the HRS is in the *Normal* resolution mode (the default after Auto Measure.) For more information about Resolution modes, refer to [“Wide/Normal/HiRes Resolution” on page 3-8](#).

Quick Tour

We have not yet mentioned amplitude accuracy. If the signal is modulated and you want to compare HRS measurements to a power meter, use the integrated trace power in the RMS mode, making sure you sweep over the entire input signal spectrum.

If your signal is an unmodulated laser with less than 2 MHz line width, use the peak detector mode and compare the marker peak value to the power meter. In making power comparisons, the HRS will be more accurate on narrower spans because the instrument sweeps slower in narrow spans. Normal mode is the most accurate resolution mode.



Using Markers

The following sections will show you how to navigate markers around the display.

The HRS allows you to:

- Use a normal/point marker.
- Use a delta marker.
- Use a bandwidth marker.
- Automatically initiate a marker search after each sweep.
- Place the marker on the memory trace.
- Save the marker values to a file after each sweep.

Normal Markers

- 1 Click  on the Setup Panel. Click *Markers On* to activate the normal marker on the trace. The Normal marker is indicated by a red square on the display.
- 2 Change the span by zooming-in and observe how the marker power changes. (You must take a sweep to update the zoom-in data.) If the marker is on a broad feature that spans several points, the marker power will decrease as the span is reduced. Reducing the span reduces the sub-span the HRS integrates over, therefore less power is reported. If the marker is on a sharp trace feature that is contained within a single trace point, the span will not affect the marker power until the span is so narrow that the power starts to divide between two points.
- 3 Click  on the Setup Panel and select the *Peak* detector. Now changing the span has little effect on the marker value. Return the HRS to RMS detection mode before proceeding.
- 4 On the toolbar, click the Object Select icon  to deactivate the zoom functions.

Hover the arrow over the marker on the trace, then click and drag. You can use your finger on the touch screen or mouse to drag the cursor. You can also enter a specific value in the Marker Freq. box. Note that the HRS will place the

Quick Tour

marker on the nearest trace point rather than exactly at the requested value.

- 5 Use the search features at the bottom of the Marker menu to move the marker around. Click *Peak Search* to put the marker on the highest trace point, then use the arrow buttons to move to the next higher peak: *Right* moves to next peak right, *Left* moves to next peak left, *Down* moves to next lower peak and *Up* moves to next higher peak. If you want to search for pits rather than peaks, select *Pit*.

When searching for anything beside the highest point on the trace, the HRS relies on the following definition of a peak: a peak must extend above the adjoining trace points by peak/pit excursion dB.

- 6 To change the Pit/Peak Excursion value, click *Setup* menu > *System Setup* > *Markers* tab. Setting the peak/pit excursion to a larger value will reduce the amount of peaks detected by the HRS.

Tip: While in the System Settings dialog, explore the other tabs to become familiar with other settings that you can control.

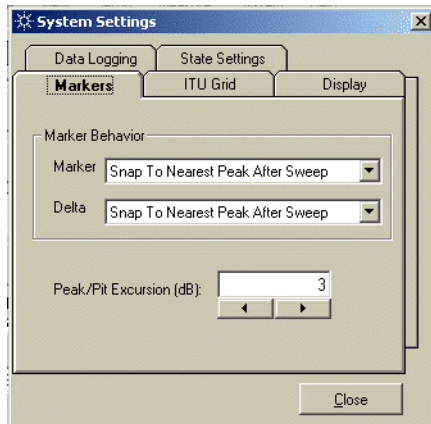

Note that settings made in this dialog will not become active until the dialog is closed.

- 7 Set the peak excursion to 15 dB, and use the search features to move the marker around. Note that it finds fewer peaks. Be sure to set the excursion back to 3 dB when you are finished.

Using a delta marker

- 1 Click **Markers...**, make sure markers are on, then select *Delta* as the Marker Type.

The delta marker is indicated by a black “x” on the display.

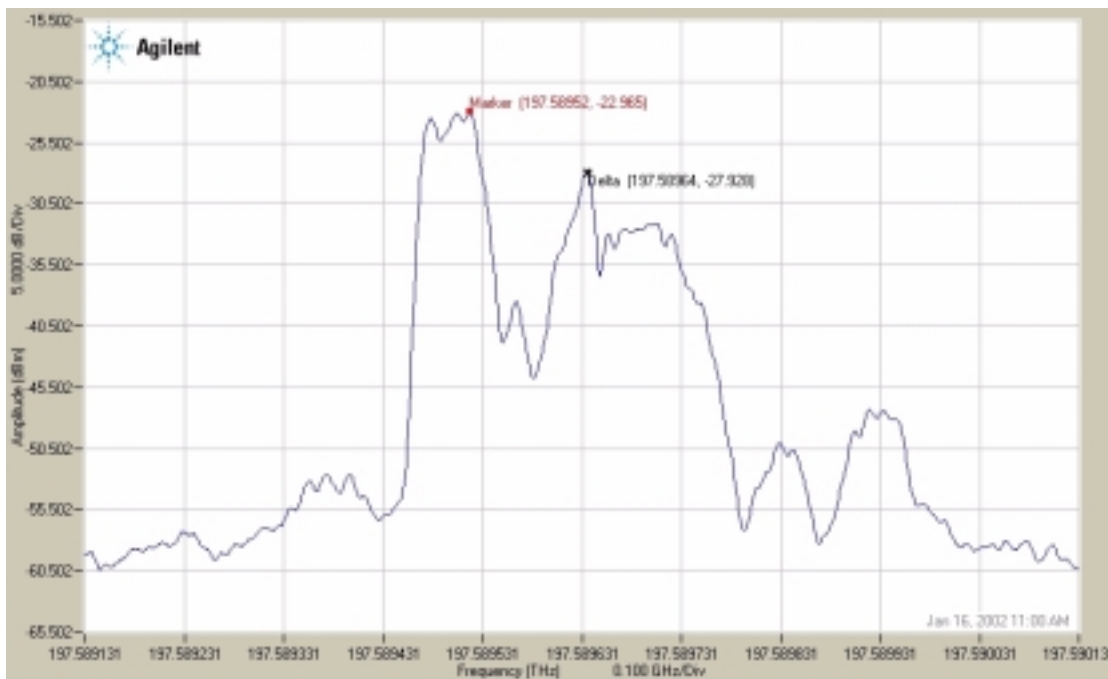

Figure 2-11. Delta Marker Measurement

The frequency and amplitude of the markers, and the difference between the markers is displayed in the Markers area at the bottom of the display.

Markers	
■ Marker:	197.58952 THz -22.965 dBm
* Delta Mkr:	197.58964 THz -27.928 dBm
Delta:	-0.118 GHz 4.962 dB

- 2 Move the delta marker just like the normal marker. You can grab it with the mouse or use your finger on the touch screen, you can also enter the desired frequency, or enter the desired frequency offset (that is, Delta Wvl or Freq) from the normal marker.

Quick Tour

- 3 Use the marker search buttons to position the delta marker.

You can choose which marker (delta or normal) to navigate with the marker search functions. In the Current Marker area in the Marker Setup Panel, click on the drop down box and make your selection from the marker search buttons.

Using a Bandwidth Marker

- 1 Click the *Markers* button, make sure markers are on, then select *Bandwidth* as the Marker Type. The normal marker is used as the reference against which two bandwidth cross hairs are placed on the trace. Usually, the normal marker would be on a peak or a pit. When the normal marker is on a peak, enter negative BW settings to indicate how many dB down to search for the band edges. When the normal marker is on a pit, enter positive BW settings to indicate how many dB up to search for the pit edges.

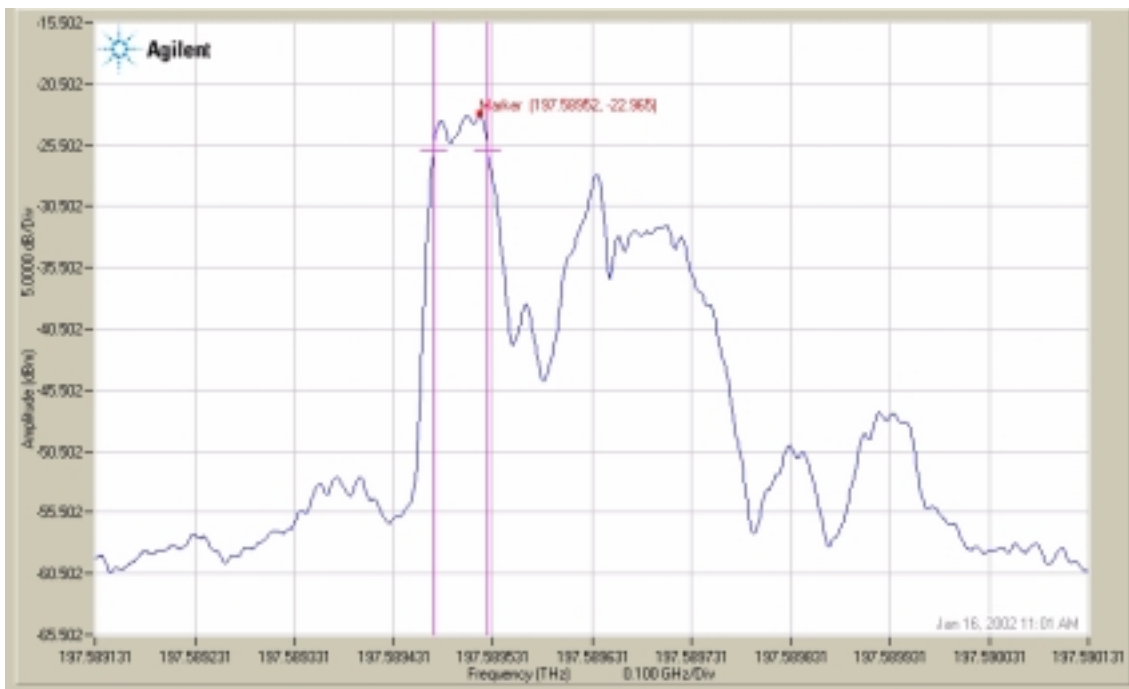

Figure 2-12. Bandwidth Marker Measurement

The resulting bandwidth is displayed in the Markers area at the bottom of the display:

Markers			
■ Marker:	197.58952 THz	-22.965 dBm	Bandwidth: 0.0547 GHz
■ Left:	197.58947 THz	-25.965 dBm	Center: 197.5895 THz
■ Right:	197.58953 THz	-25.965 dBm	BW Setting: -3.0 dB

The position of the marker and the bandwidth cross hairs are noted, as well as the measured bandwidth and the center frequency (calculated as mean of left and right cross hair frequencies.)

- 2 Place the marker on a peak and try entering different negative bandwidth settings to see how the markers are positioned.
- 3 Place the marker on a pit and try entering different positive bandwidth settings to search for notches instead of pass bands.

Perform a marker search after each sweep

You can specify that the marker automatically finds the peak at the end of each sweep. This will update the parameters as you tune or modify the device being tested.

- 1** Set up a sweep with several peaks on the display. Find the second highest peak on the trace, and place the marker on the peak about 1 dB below the highest point. Take a sweep by clicking *Single Sweep*. Note that the marker snaps to the nearest peak at the end of the sweep. This is the default mode.
- 2** From the menu bar, click *Setup > System Setup > Markers* tab. In the Marker Behavior area select *Snap to Highest Point after Sweep*. In this mode, the marker will be moved to the highest peak at the end of each sweep.

The other options are:

Snap To Nearest Point causes the marker to ride the trace amplitude without moving left or right.

Float allows the marker to lift off the trace and simply mark a place on the plot.

Snap To Highest Point After Sweep performs a peak search at end of sweep.

Snap The Nearest Peak After Sweep searches left and right for neighboring peaks, and places the marker on the nearest one.

Snap To Nearest Point On Any Trace allows you to drag the marker onto other traces that the HRS might put on the display such as a reference trace or the Line Fit. Once on the trace, the marker will stay there, riding the amplitude without moving left or right.

In this case, we are interested in *Snap To Highest Point After Sweep*. The selection will not become active until you close the setup dialog. Take a sweep by selecting *Single Sweep*, and note how the marker always finds the highest peak.

Place marker on the memory trace

It is possible to place the marker on the reference trace or on the active trace. Normally, the marker will remain on the active trace, but if you select *Snap To Nearest Point On Any Trace* in the Marker Setup dialog, you will be able to drag the marker onto the reference trace.

- 1 Take a sweep of the signal source.
- 2 Save the trace by clicking the *Measurement* button on the Setup Panel. At the bottom of the Measurement menu, there are two buttons to control the Reference trace. Click *Save* to save the active trace as the reference trace. The reference trace appears as a second trace on the screen, although it may be hard to see as it is overlaying the active trace.
- 3 Change the input signal so you can see the reference trace. Tune the input wavelength slightly, or decrease the amount of power, and then click *Single Sweep*.
- 4 From the menu bar, click *Setup > System Setup > Markers* tab. Select the marker behavior *Snap To Nearest Point On Any Trace*.
- 5 Use the mouse to drag the marker on to the reference trace.

Put the marker back into *Snap to Nearest Peak* and *Clear* the reference trace when you are finished.

Save the marker values to file at the end of each sweep

The HRS has the capability of saving key trace information to a log file at the end of each sweep. This is very useful for monitoring the behavior of a signal over time. Refer to “Data Logging” on page 4-30 for a description of the specific data that can be saved. In general the markers, the integrated trace power, and the mean wavelength are stored. The data is exported to a daily log file, which is changed at midnight each day. You cannot select the name of the file or where it is stored.

- To turn logging on, click *Setup > System Setup > Data Logging* tab and select *Data Logging On*. You can specify the number of sweeps between data collection. When you close the dialog, logging will start with the next sweep. A message will appear in the message area if a new logging file has been opened.

Tip: You can view the measurement results as it is logged. From the menu bar, click *View > Data Logging Watch Window*.

Understanding Auto Measure

When you first connect a signal to the HRS, there are a sequence of steps you should take to find the signal and optimize the system to receive the signal. The Auto Measure function follows a super set of that sequence. If you know something about the input signal, you might wish to save time and do a manual acquisition of the signal. This section describes what auto measure does in detail, so that you can replicate the portions of the sequence that apply to your input signal.

1 Initial Attenuation

Before taking any data, the HRS sets the attenuation to 15 dB. This allows strong signals, up to the receiver peak power input limit, to be observed without saturation. If no signal is found with 15 dB of attenuation, the attenuation is reduced to 0 dB. At the end of Auto Measure the attenuator will be set by the Signal to Noise Optimization function, which will attenuate the input signal for maximum signal to noise ratio.

The manual attenuation selection is found in the Amplitude menu under the Setup Panel.

2 Broad sweep in wide band resolution mode to find the signal

The first task of Auto Measure is to find the signal. The HRS employs a special detection mode that allows fast, less accurate sweeps to acquire the signal. The first sweep is taken with the widest span allowed by the HRS. If no signal is found, the attenuation is reduced from 15 dB to 0 dB and another equally wide sweep is taken.

The wide band sweep in Auto Measure will cover both C and L bands by default. If your signals are always in a particular band, you can make this sweep faster by entering a narrower span in the Auto Measure setup panel. (Setup > Auto Measure Setup).

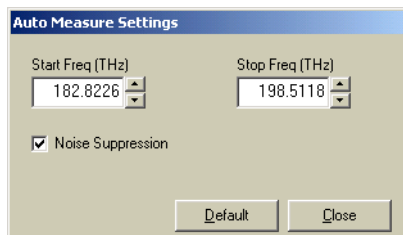

If you wish to search for the signal yourself, select Wide resolution and enter the desired center and span. Once the signal has been found, you will want to return to Normal resolution. The Resolution selection is found in the top, middle of the display.

NOTE

Units shown are in Hz. If the x-axis mode is set to wavelength, this dialog will also have units of wavelength. The x-axis mode is set by selecting the *Frequency* (if in frequency mode) or *Wavelength* (if in wavelength mode) button from the Setup Panel. Different spectral configurations require a new noise suppression routine to balance the mixer.

Note there is also a check box to control whether noise suppression is performed during auto measure. Normally, you will want to perform noise suppression. It saves time to omit it, but you need to take care to occasionally perform noise suppression manually if you do.

3 Narrow sweep around peak

If a signal is found, the HRS will return to Normal resolution mode, center a 300pm/30 GHz sweep around the largest signal observed, and then center the trace on the display. If there is no signal found, an error is reported.

You can do this manually by using the Pan Display icon  to center the peak on the display.

4 Noise Suppression to balance receiver for this signal at this polarization.

With the signal accurately acquired, the HRS enters a self-adjustment mode to optimize the receiver's ability to reject noise and AM modulation. The HRS employs a balanced mixer, but the optimum balance of the mixer depends on the input polarization and wavelength. Each time you connect a new signal or change the wavelength of the input signal, you will want to rebalance the receiver. Auto Measure will, in its default mode, perform this adjustment.

To perform noise suppression, connect the signal under test and make sure the attenuator is set appropriately. Then select *System* from the main menu bar at the top of the display, and then choose *Operations*, and finally *Noise Suppression*. The HRS will take a number of sweeps as it optimizes the receiver for your input signal.

5 Narrow sweep, 150 pm /16 GHz

After noise suppression, the HRS takes a 150 pm sweep in normal resolution mode.

6 Signal to noise optimization

At this point in Auto Measure, the attenuator has been set to either 15 dB or 0 dB. Depending on the signal power, this may not be optimal. The HRS will take sweeps and adjust the attenuator until the peak power is within the most linear region of the receiver.

Theory of Operation 3-2
Tunable Laser Measurements 3-13
Transmitter Measurements 3-23

Using the HRS

Theory of Operation

The HRS system allows extremely fine sub-picometer spectral resolution measurements on tunable lasers, transmitters, and systems. The following sections describes how the High Resolution Spectrometer (HRS) was designed to make these measurements. Topics include:

- “How the HRS Detects a Signal”
- “RMS vs. Peak Detection”
- “Wide/Normal/HiRes Resolution”
- “Tunable Laser Sweep Rate”
- “Temperature and Vibration”
- “Signal/Receiver Interaction”
- “Spurious Responses”

How the HRS Detects a Signal

The HRS implements a heterodyne optical receiver, also called a coherent receiver. In the simplest sense, it could be thought of as a 15 MHz wide optical filter with over 60 dB of rejection followed by a fast power meter. As the optical filter is tuned (or swept) across wavelength, the power meter will detect power as a function of wavelength (or optical frequency).

The HRS achieves the narrow filter by mixing a tunable laser with the input signal. Mixing occurs inside a photodiode and an electrical filter selects a portion of the output spectrum. The energy detected at the output of the filter is proportional to the optical energy centered at the wavelength of the tunable laser. As the tunable laser is swept across wavelength, the effective image of the filter is swept across wavelength and the HRS measures the optical spectrum.

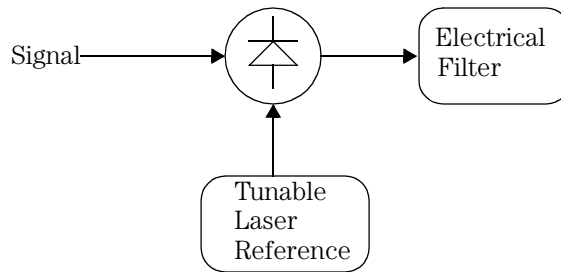

Figure 3-1. Simplified Block Diagram

Suppose we denote the E-field of the input signal as an amplitude modulated sine wave:

$$signal = A(t)\sin w_{du}t$$

Borrowing a convention from radio frequency engineering, the tunable laser inside the HRS is referred as the Local Oscillator (LO). It is denoted as a simple tone (whose frequency will later be swept):

$$LO = B\sin w_{LO}t$$

Theory of Operation

The signal and the LO are combined optically (with the same polarization), so that the E-fields add. When the summed E-fields excite the photodiode, the output current will be proportional to the incident optical power. The way these equations are developed, the electrical output will be proportional to the square of the input E-field:

$$\begin{aligned} (\text{signal} + \text{LO})^2 &= (A(t) \sin(w_{dut}t) + B \sin(w_{LO}t))^2 \\ &= A^2(t) \sin^2(w_{dut}t) + 2A(t)B \sin(w_{dut}t) \sin(w_{LO}t) + B^2 \sin^2(w_{LO}t) \end{aligned}$$

Note, however, that any term above a few GHz will not conduct electrically. This allows us to eliminate any terms at or above w_{dut} or w_{LO} . The following trigonometric identities is used to resolve the nonlinear functions of sin:

$$\sin(A) \sin(B) = \frac{1}{2} \{ \sin(A - B) + \sin(A + B) \}$$

$$\sin^2 A = \frac{1}{2} - \frac{1}{2} \cos 2A$$

And we eliminate the terms at or above w_{dut} or w_{LO} :

$$= \frac{1}{2} \left\{ A^2(t) - 2A(t)B \sin(w_{dut} - w_{LO})t + B^2 \right\}$$

There is a term at the difference frequency between the DUT and the LO. This is the heterodyne term, and it is the heart of the HRS detection. There are some things to note about this equation:

- The heterodyne term varies linearly with the E-field $A(t)$. You might expect the photodiode output to be proportional to power, but the heterodyne term is a cross term. It has the units of power because of the product $A(t)B$, but as long as we hold B constant, the receiver will respond linearly to the E-field.
- If the local oscillator is swept, the heterodyne term will also sweep at the same rate, crossing zero Hertz when the LO signal is at the same wavelength as the input signal. An electrical filter is used to truncate the bandwidth of the heterodyne signal, so the heterodyne receiver only detects power when the LO is close in wavelength to the input signal.

- If the input signal covers many frequencies, either because of the amplitude modulation term $A(t)$ or because of chirp on w_{dut} , the electrical filter mentioned above selects only power that is near the LO wavelength, inside the filter bandwidth.
- As mentioned above, the heterodyne term will only occur if the E-fields add. If the LO and the input signal wander out of the same polarization state, the heterodyne term will disappear. The HRS has internal mechanisms so that it detects power at any input polarization. The Polarization Dependence specification shows the residual power measurement error due to polarization change. Refer to “Amplitude Specifications” on page 7-7.
- The heterodyne term scales linearly with the LO power, which means that any variations in the output power in the tunable laser (that is, the internal LO) have to be corrected. The HRS has an internal calibration mechanism to minimize this effect.
- The power in the AM term appears about DC: $A^2(t)$. This term appears whether or not the LO is near in wavelength. Basic photodiode operation produces output current proportional to input power. If the input power drops 1 dB, the output current drops 1 dB and the output power drops 2 dB. If the AM term is broadband (for example, a 40 Gbit stream) it can easily swamp the heterodyne term.

Modulation or noise on the input signal make most heterodyne systems useless. The HRS employs a balanced mixer instead of a simple coupler and photodiode. The balanced mixer is composed of several optical components and more than one photodiode such that the $A(t)$ term is canceled inside the receiver. The optimum mixer balance depends on the input signal wavelength and polarization, so it is necessary to rebalance the receiver frequently. The balance operation is part of the Auto Measure function, and can also be run at any time by selecting System > Operations > Noise Suppression.

During a sweep, the detectors run continuously, logging power as a function of time using linear-responding power detectors. At the same time, a wavelength detection system consisting of two interferometers continuously logs the output wavelength of the LO. The two interferometers have different free spectral ranges, allowing the HRS to unambiguously detect wavelength over a 100 nm span.

RMS vs. Peak Detection

After the sweep is complete, the measured power is taken with the measured wavelength and converted to the display trace in a process called detection. Since power is monitored continuously but the trace consists of a finite number of trace points, the HRS has to aggregate the power data into unique-valued trace points. This process of aggregation can mask useful information, so the HRS provides two different methods.

RMS Detection

The most useful detection is called RMS, which integrates the detected power over the wavelength sub-span corresponding to a given trace point. For example, a 1001 point sweep over 100 GHz associates a 100 MHz sub-span with each trace point. For RMS detection, the HRS integrates all the power observed while the LO was within the 100 MHz sub-span centered on a trace point, and associates that value with the trace point. The HRS markers always read a specific trace point, they do not interpolate in between points. Note that the 100 MHz sub-span is also referred to as the detection bandwidth, the resolution bandwidth and the resolution. It is displayed in the lower right hand corner of the display as *Resolution*.

To convert the RMS trace to integrated power, the system adds up the individual trace points (after converting to watts). If the sweep covers all the spectral components of the signal, the total power will agree with a power meter.

To convert a trace point to power spectral density, divide by the sub-span for that point:

$$sub\text{-span} = \frac{span}{\# \text{ trace points} - 1}$$

$$power \text{ spectral density} = \frac{marker \text{ value}}{sub\text{-span}}$$

Because the power is integrated over the sub-span, a trace point in RMS mode will decrease in power as you reduce the span of the sweep. The same power gets distributed over more points, so each point reads lower power. The exception to this is when measuring very sharp trace features: if the feature is narrower than a trace point, the same power is captured even if the span is reduced, until the span is reduced so that the feature is no longer narrow compared to a trace point. It is possible, in RMS mode, to measure a signal with both broad and narrow band components such that as the span is narrowed, the broadband components decrease in power but the narrow components remain stable.

Peak Detection

The other method of aggregating the continuously measured power into trace points is to take the peak trace power observed over the sub-span associated with each trace point. This works well when a trace feature is much narrower than the sub-span associated with a single trace point. For example, if you are looking at clock feed through on top of a 2.5 Gbit PRBS modulated signal.

Note that in peak mode, the power detected is still RMS power. For example, if you measure an unmodulated laser with less than 2 MHz line width in peak mode, a single trace point will agree with a power meter because the peak RMS power is the total power for that laser. For an unmodulated, narrow-line laser, RMS and peak mode will give the same answer.

Peak mode is most useful when there is a broad band feature partially obscuring a narrow feature. In RMS mode, the power from the broadband feature is integrated across the sub-span associated with each point. In peak mode, the HRS uses only the largest power observed.

Because the peak mode does not reflect all the power observed in the sub-span for a trace point, you cannot reliably estimate total power from the peak detector for modulated or noisy signals.

Peak mode is relatively insensitive to span changes. Increasing the span increases the sub-span searched for a peak, but does not change the way the power was detected.

Wide/Normal/HiRes Resolution

One of the difficult choices in designing a receiver is the balance between the need to sweep fast and the need for low noise and high resolution. The HRS offers three different resolutions that allow you to select faster sweeps with increased noise and reduced accuracy, or slower sweeps with the best resolution.

Normal Resolution

Normal resolution should be used for most measurements on the HRS. This mode combines good dynamic range, 15 MHz resolution, and reasonable speed. It offers the best amplitude accuracy and the same wavelength (or frequency) accuracy as the HiRes (high resolution) mode. The algorithms for compensating mixer balance, noise floor, and LO power are all optimized for use in this mode.

Wide Resolution

Wide resolution is provided so that you can locate a signal quickly before zooming in on it. Instead of using higher-accuracy digital corrections, this mode uses the fastest available laser sweep rate and special analog compensators. In exchange for a faster sweep, wide resolution degrades amplitude accuracy, wavelength accuracy, scale fidelity, and the ability to reject broadband noise and modulation on the input signal.

While it is not generally recommended to use the wide mode on spans less than 1 nm (125 GHz), Wide resolution works very well for input signals that do not have high noise or modulation components within the receiver bandwidth. The user interface allows you to switch between wide and normal modes for spans less than 1 nm. If, for example, you wanted to take fast sweeps while you adjust your device, try switching to wide resolution. When you want to take a final sweep, switch back to normal.

HiRes

When measuring unmodulated lasers, it is possible to use digital post-processing filters to improve the resolution of the HRS. With the HiRes mode of the HRS, you can resolve spectral components as a little as 1 MHz apart. The post-processing is very time-consuming: you will want to use normal mode to locate the signal and go to as narrow a sweep as possible before selecting HiRes. The post-processing is configured to optimize frequency resolution over amplitude accuracy or amplitude resolution. A signal that appears stable when viewed in normal mode is likely to vary several dB from sweep-to-sweep in HiRes mode. The amplitude variation comes from two factors: short term variations in the LO sweep rate and from the mechanism that allows the HRS to detect power with any polarization.

Tunable Laser Sweep Rate

The HRS uses a tunable laser to sweep wavelength. The faster the laser sweeps, the less time a signal has to charge the detectors. Thus, the faster the sweep, the lower the amplitude accuracy. The HRS supports a discrete set of sweep rates: 1, 5, 10 and 40 nm/s. The sweep rate is increased automatically as the span is increased. The current sweep rate is displayed in the lower right hand corner of the display in the Status area.

Temperature and Vibration

As mentioned above, the heterodyne detection relies on the E-field of the input signals adding. Anything that changes polarization or optical phase can affect the HRS detectors. As such, temperature changes and vibration will affect measurements results with the HRS. The HRS is designed to be used in a stable environment with no heavy equipment operating nearby and with temperature comfortable for human beings. While Agilent does not recommend placing the HRS in a constant-temperature chamber, you will get better results if you avoid sudden temperature changes that might be associated with doorways, heaters or air conditioning vents.

Signal/Receiver Interaction

The HRS receiver does not respond to all input signals the same way. For example, a unmodulated narrow line width external cavity laser presents different measurement challenges than a 2.5 Gbit directly modulated DFB. This section discusses some specific situations that might arise:

- Noise Suppression
- Multiple Carriers
- Possible IF Regeneration
- Slow Modulation Components

Noise Suppression As discussed above, the HRS uses a balanced receiver whose optimum balance depends on the wavelength and polarization of the input signal. If the input signal has a large AM (amplitude modulation) component, whether from data modulation, other channels, or relative intensity noise (RIN); you may need to frequently repeat noise suppression to get maximum dynamic range. (From the menu bar, click System > Operations > Noise Suppression.)

A less obvious concern is if you perform noise suppression for one input signal, and then go to a different input signal. If you do not redo the noise suppression, you will be using the configuration for the last signal, which may not be optimum!

Multiple Carriers The HRS is wavelength selective. If there are multiple carriers present the HRS can still make measurements. However, it is possible to swamp the receiver with too much power. For example, the HRS is designed to handle -5 dBm peak power. If you configure the input signal so the channel of interest is measured at -5 dBm, power from the other channels will start to compress the photodiodes. The accuracy of the HRS degrades considerably when the combined average input power exceeds $+5$ dBm with zero input attenuation. There will be no warning that the out-of-band energy is compressing the receiver, so it is up to the user to keep the peak power on screen below -5 dBm and the total input power below $+5$ dBm. If you use input attenuation, the peak and total power limits increase dB-for-dB with attenuation, to the attenuator limit of $+23$ dBm of total input power.

Please note that any modulation on the other carriers will be detected by the HRS photodiodes, and will rely on noise suppression to cancel them out. It may be necessary to perform noise suppression frequently in these cases.

Possible IF Intermodulation

If two strong carriers close in wavelength are input into the HRS, it is possible to observe some signal regeneration. That is, there appears to be energy at the difference between the two inputs when in fact there is none. This can look like full-wave mixing. For example, say two carriers F_1 and F_2 are input into the HRS. If regeneration occurs, energy will appear at $F_1 - (F_2 - F_1)$ and $F_2 + (F_2 - F_1)$, assuming $F_1 < F_2$.

A similar effect is possible with AM modulation, although it has never been observed. If a carrier has AM modulation with two coherent tones, the same regeneration could occur.

Slow Modulation Components

The HRS uses an electrical filter to limit the detected power to within 15 MHz of the local oscillator. If the input signal has strong modulation components below 15 MHz, the components may enter the electrical filter. If the components are small relative to the total power in modulation sidebands, the noise suppression will eliminate them. However, increasing the power in the slow modulation components will eventually start to distort the noise floor, as the AM component phases in and out of the heterodyne term. If you observe a noise floor that appears sinusoidal, or raised sine, check your input signal for strong modulation components below 15 MHz.

Spurious Responses

An ideal heterodyne instrument would have a local oscillator with effectively zero line width and no side modes. Just as the local oscillator can convert features of the input signal into a heterodyne term detected by the receiver, the input signal can convert features of the local oscillator into a heterodyne term detected by the receiver. The local oscillator features scale linearly with the input signal, making them indistinguishable from features of the input signal. The HRS local oscillator is guaranteed to have at least 40 dB spurious free range. The largest spurs on the HRS fall very close to ± 4 GHz offset from the main signal. Harmonics at 8 and 12 GHz offsets are successively lower. There is also a single pair of symmetric side-modes at ± 200 MHz from the carrier frequency. The figure below shows an example of a measurement made on an external cavity laser that has a pair of side modes at intervals of 2 GHz from the carrier frequency. Note that the HRS system LO side-modes will vary from system to system, and the amount of side-mode power detected depends on the input signal.

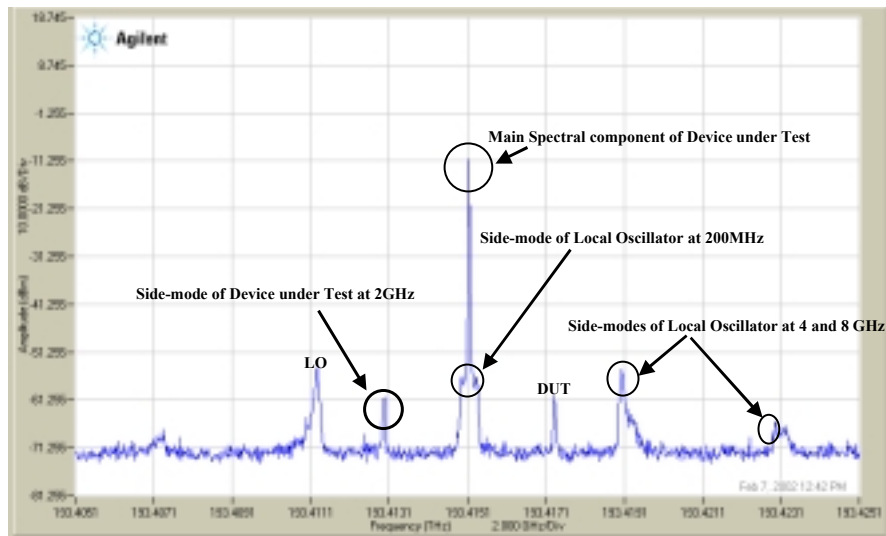

Figure 3-2. Location of HRS Spurs

Tunable Laser Measurements

Now that you understand the theory of operation of the HRS, the following measurement procedures will show you how to use the HRS to measure the characteristics of your laser. This section includes:

- [Using Peak Detection to Measure Peak Amplitude](#) 3-13
- [Using High Resolution to View Details of the Response](#) 3-15
- [Measuring Line Width of a Laser](#) 3-18
- [Measuring Side Mode Suppression Ratio \(SMSR\)](#) 3-21

Using Peak Detection to Measure Peak Amplitude

This procedure uses peak detection to measure the peak amplitude of an external cavity laser (ECL) with very narrow line width (< 2MHz). Peak detection is useful for measuring the marker amplitude of a peak with the accuracy of a power meter.

- 1** From the toolbar, click **Auto Measure** to find the largest signal in the response.
- 2** From the Setup panel click the **Frequency/Wavelength** button. Reduce the span to approximately 3 GHz or 25 pm.
- 3** From the toolbar:
 - a** Click on the **Pan** icon (hand) and move the signal to the center of the display.
 - b** Click **Continuous Sweep**.
 - c** Click the Resolution box and select **Normal**.
- 4** From the Setup panel:
 - a** Click the **Amplitude** button and select **Peak** detection.
 - b** Click the **Markers** button and select **Markers On**. Set Marker Type to **Normal**, then click **Peak Search**.

Using the HRS
Tunable Laser Measurements

The Markers area of the Information Panel (located below the bottom of the display) will show the marker measurement results.

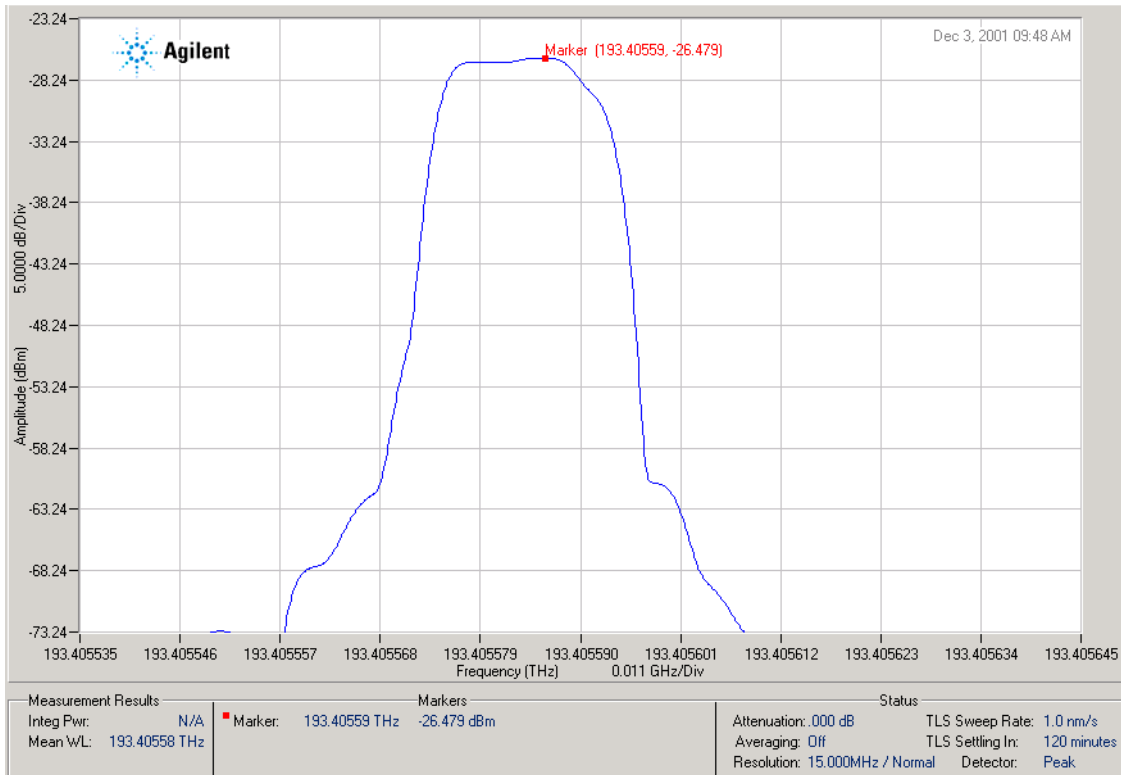

Figure 3-3. Measuring peak amplitude using peak detection

Using High Resolution to View Details of the Response

With the high resolution mode of the HRS, you will be able to view characteristics of a laser that you probably have not been able to see before. This procedure shows you how to measure a laser response first with normal resolution, and then with high resolution.

- 1** From the toolbar, click **Auto Measure** to find the largest signal in the response.
- 2** From the toolbar, click Resolution and select **Normal**.
- 3** From the Setup panel click the **Frequency/Wavelength** button. Reduce the span to approximately 0.10 GHz or 1 pm.
- 4** From the toolbar:
 - a** Click on the **Pan** icon (hand) and move the signal to the center of the display.
 - b** Click **Continuous Sweep**.
 - c** Click the Resolution box and select **Hi-Res** and compare the results with the normal resolution measurement.

Using the HRS
Tunable Laser Measurements

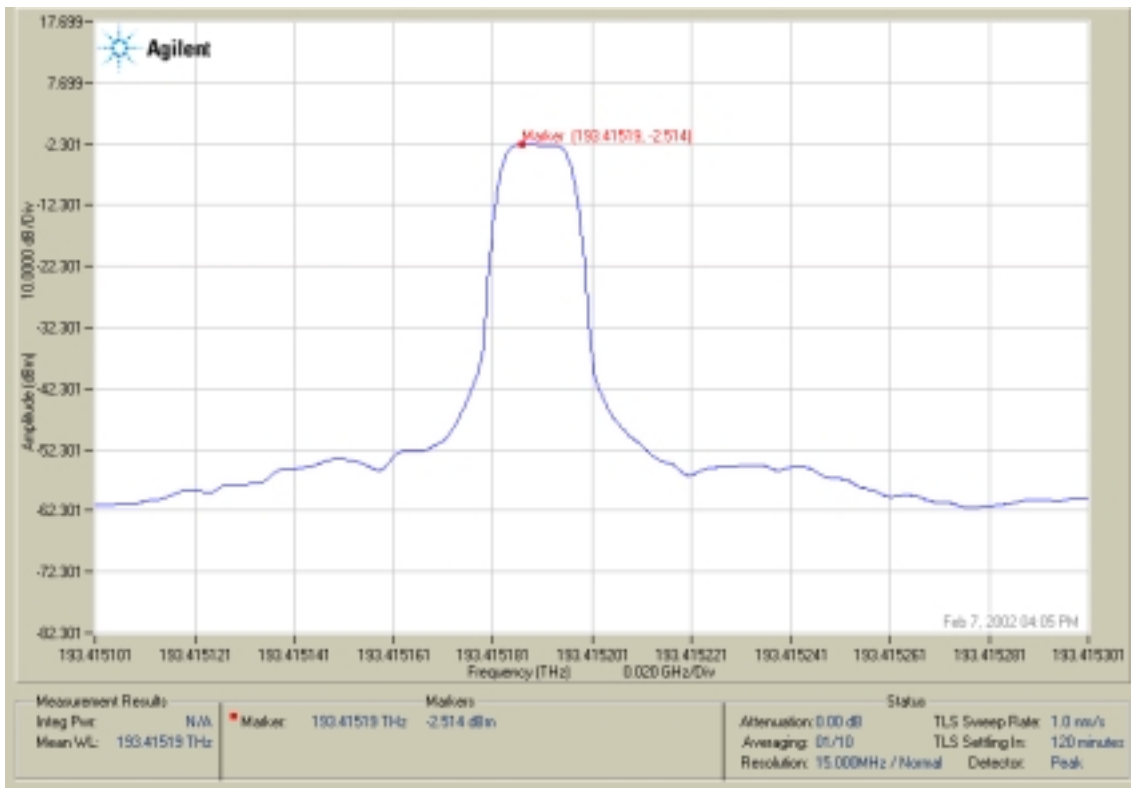

Figure 3-4. Response measured with Normal Resolution

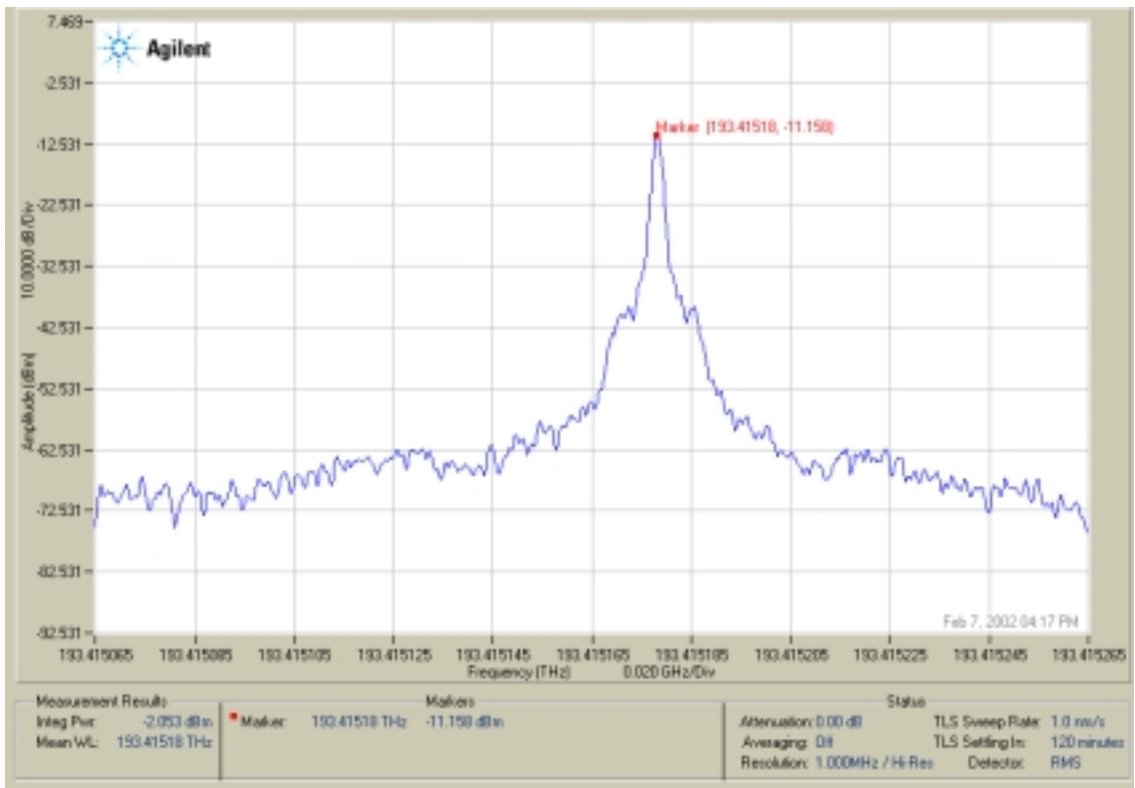

Figure 3-5. Response measured with Hi-Resolution

Measuring Line Width of a Laser

This procedure will show how to accurately measure the line width of an Distributed Feedback Laser (DFB).

- 1** From the toolbar, click **Auto Measure** to find the largest signal in the response.
- 2** From the Setup panel, click the **Measurement** button. Select **Linewidth** measurement and **Plot Lorentzian Curve**.
- 3** Click and drag the lower limit linewidth marker to an amplitude above the point where the Lorentzian curve and trace align. Refer to [Figure 3-6](#).

You want to position the line width markers at the point where the signal best matches the Lorentzian curve. Notice that this DFB laser has relaxation oscillations that do not follow the shape of the Lorentzian curve.

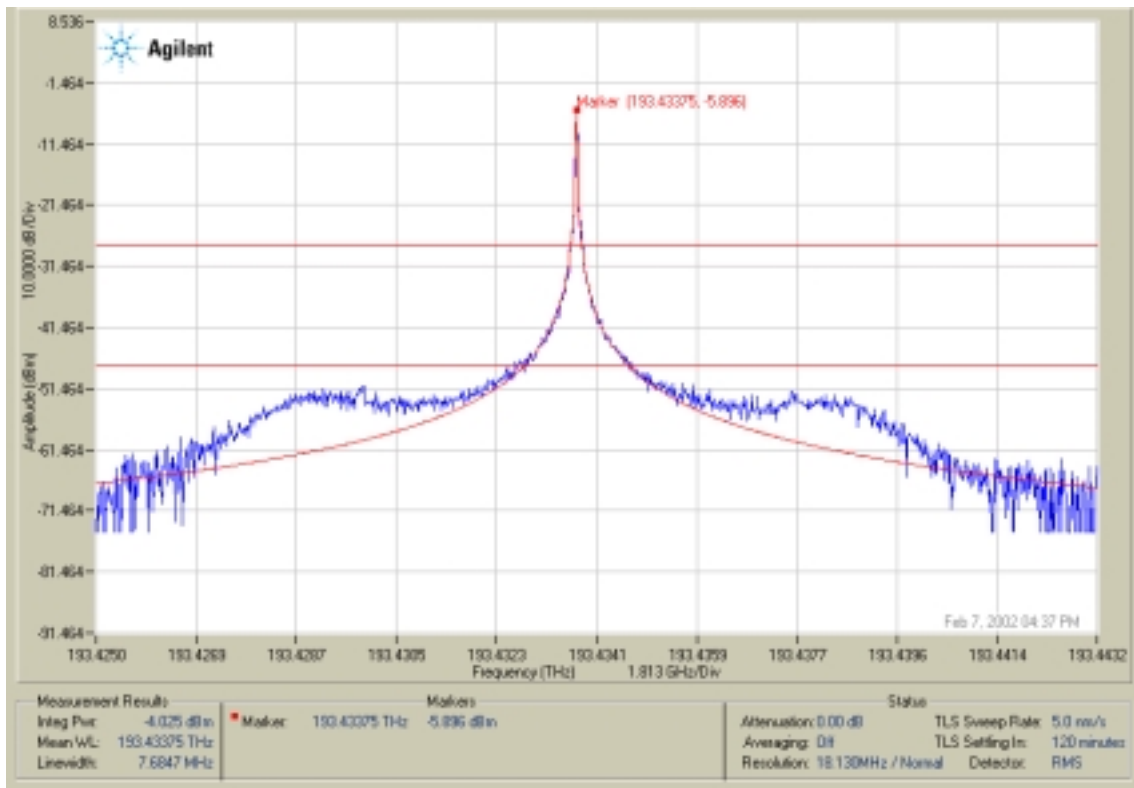

Figure 3-6. Position lower marker where trace matches lorentzian curve

- 4 From the Setup panel, click the **Frequency/Wavelength** button and reduce the span until the relaxation oscillations are not included in the measurement span.
- 5 Click and drag the upper limit linewidth marker to an amplitude below the point where the Lorentzian curve and trace align.

Notice, in [Figure 3-7](#), that there is a bowing of the trace about 2 divisions down from the peak that does not match the Lorentzian curve. Make sure to place the upper limit marker below this point. This bowing is probably caused by harmonics of the signal. Including this area in the linewidth markers would not give an accurate measurement. The linewidth measurement results are display in the lower left-side of the display.

Using the HRS
Tunable Laser Measurements

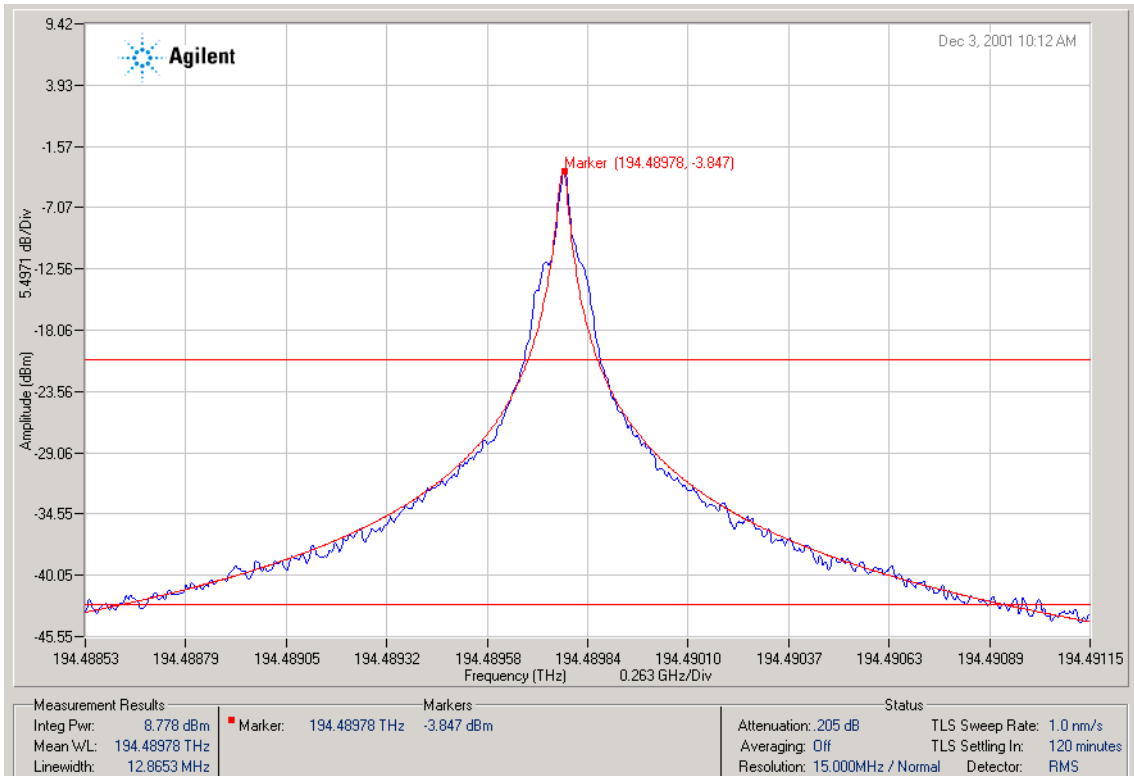

Figure 3-7. Position upper marker where trace matches lorentzian curve

Measuring Side Mode Suppression Ratio (SMSR)

This procedure will show you how to measure the frequency and amplitude difference between the main mode and the side mode of a tunable, narrow linewidth laser.

SMSR (side mode suppression ratio) is the amplitude ratio in dB of the main spectral component and the largest side mode (not necessarily the first side mode) within the current trace. This is affected by both wavelength span and peak excursion.

- 1** From the toolbar, click **Auto Measure** to find the largest signal in the response.
- 2** From the Setup panel, click the **Frequency/Wavelength** button and reduce the span so that just the main mode and side mode are on the display.
- 3** From the Setup Panel, click the **Markers** button. Click **Markers On** and **Delta** as the Marker Type.
- 4** In the Current Marker area, click **Peak Search** to place the red marker (reference marker) at the highest point on the trace.
- 5** Click and drag the delta marker (black “x”) to the peak of the side mode. The measurement results are displayed in the Markers area of the Information Panel (located at the bottom of the display).

Using the HRS
Tunable Laser Measurements

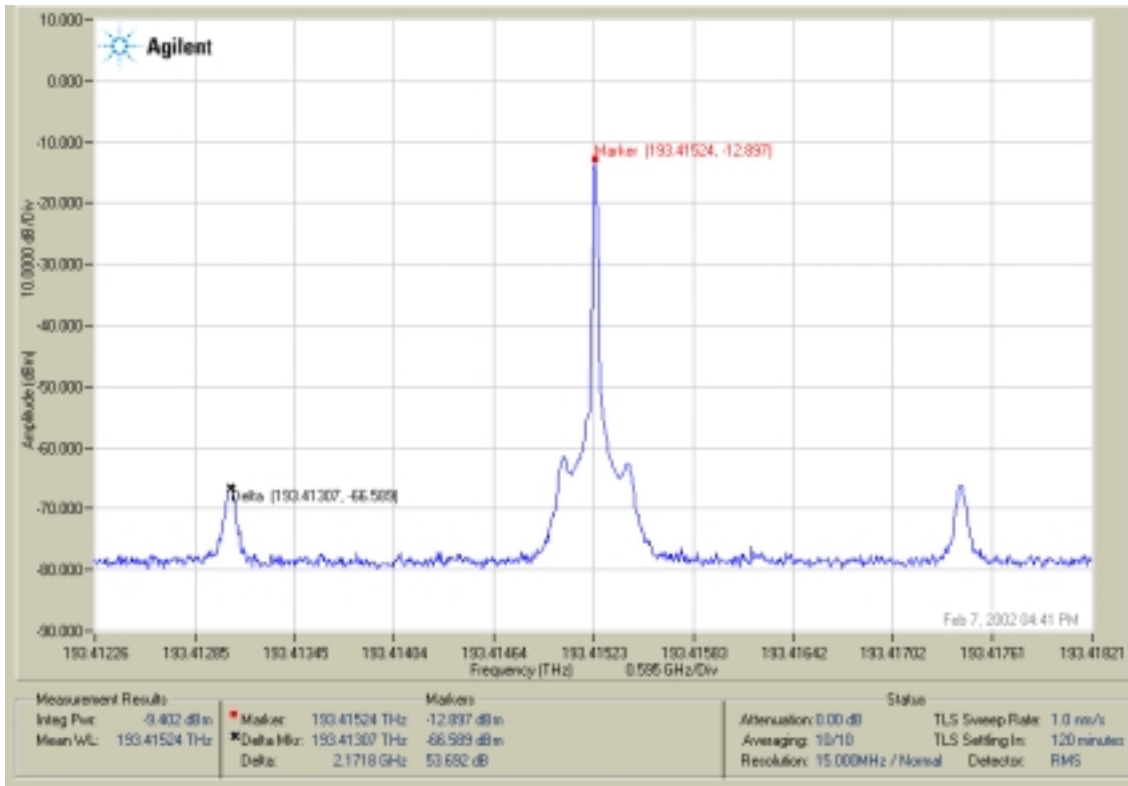

Figure 3-8. Measuring Side Mode Suppression Ratio

Transmitter Measurements

The following measurement procedures will show you how to use the HRS to measure the characteristics of a modulated transmitter. This section includes:

[Using the ITU Grid](#) 3-23

[Modulated Narrowband Laser Responses](#) 3-28

Using the ITU Grid

The HRS has the ability to overlay a grid of frequencies as defined by the International Telecommunication Union (ITU). The grid is used to align and verify alignment of transmitted signals. The standard uses a frequency grid with a reference of 193.1 THz with channel spacings as integer number of 100 GHz away from the reference. Although not defined by the ITU, the grid can be spaced at 100 GHz, 50 GHz, 25 GHz, 12 GHz, or 6.25 GHz.

If Wavelength is selected for the x-axis (Wavelength menu, X Axis Mode), these values are converted from frequency to wavelength.

From the menu bar, click **Setup > System Setup > ITU Grid**.

Under the ITU Grid tab, select **Display ITU Grid** and then select the desired grid spacing.

Transmitter Measurements**Aligning a Modulated Laser on the ITU Grid**

Compare [Figure 3-9](#) with [Figure 3-10](#). With the ITU grid turned on, you can easily see the shift in frequency of the DFB laser with the presence of modulation. Always align the center frequency onto the grid with modulation turned on.

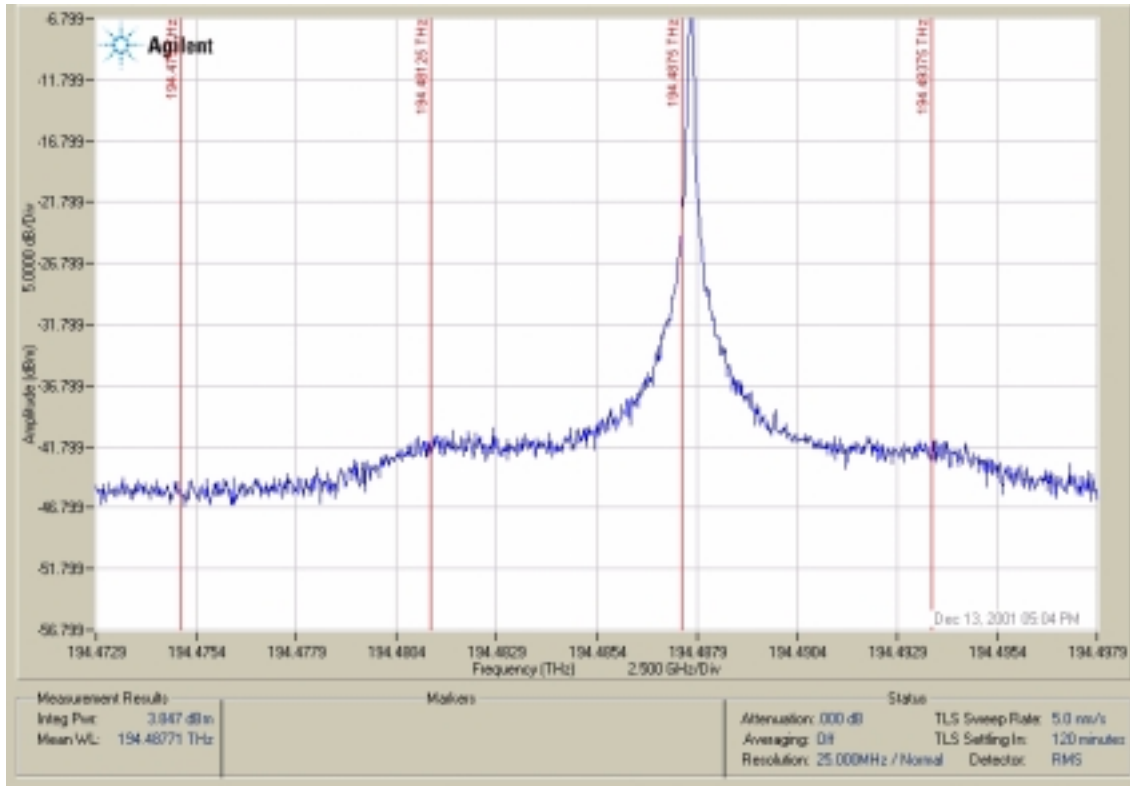

Figure 3-9. Unmodulated DFB Laser

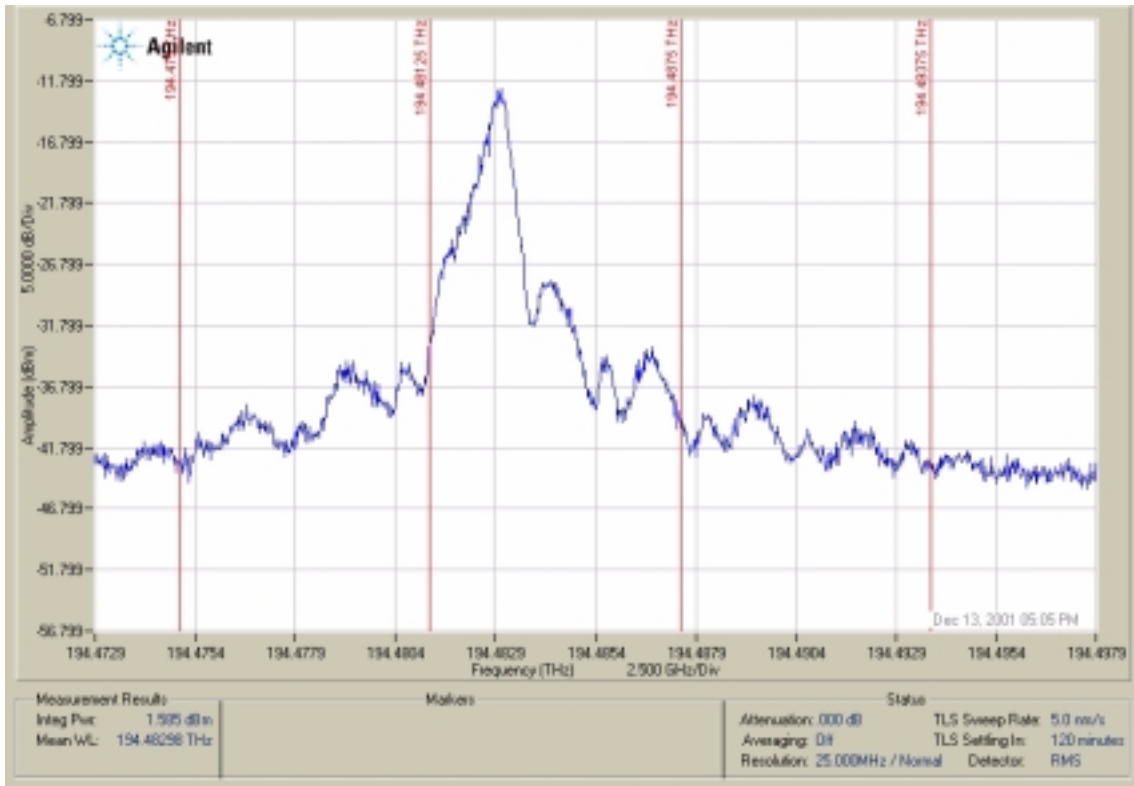

Figure 3-10. Modulated DFB Laser with Chirp

Transmitter Measurements**Determining the Mean Wavelength of a Signal**

Figure 3-11 shows the response of a modulated laser that has chirp. Notice that the response is not symmetrical on each side of the peak marker. Aligning the peak marker to the ITU grid does not necessarily place the maximum power (that is, integrated power) onto the grid. In this case, you should align the mean wavelength onto the grid where the integrated power will be at the maximum amplitude.

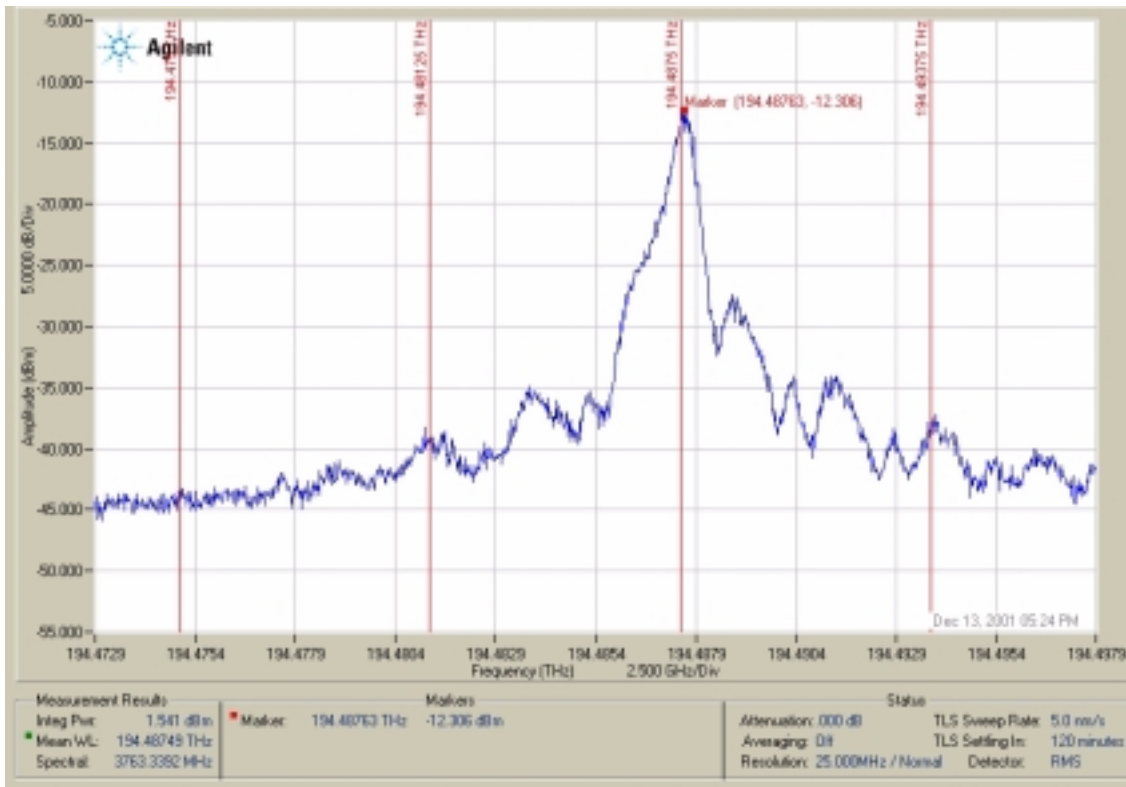

Figure 3-11. Peak Wavelength Versus Mean Wavelength

Aligning Multiple Signals onto the ITU Grid

Figure 3-12 shows the alignment of multiple signals along the ITU grid. You can choose standard ITU grid spacings of 6.25 GHz, 12.5 GHz, 25 GHz, 50 GHz, and 100 GHz.

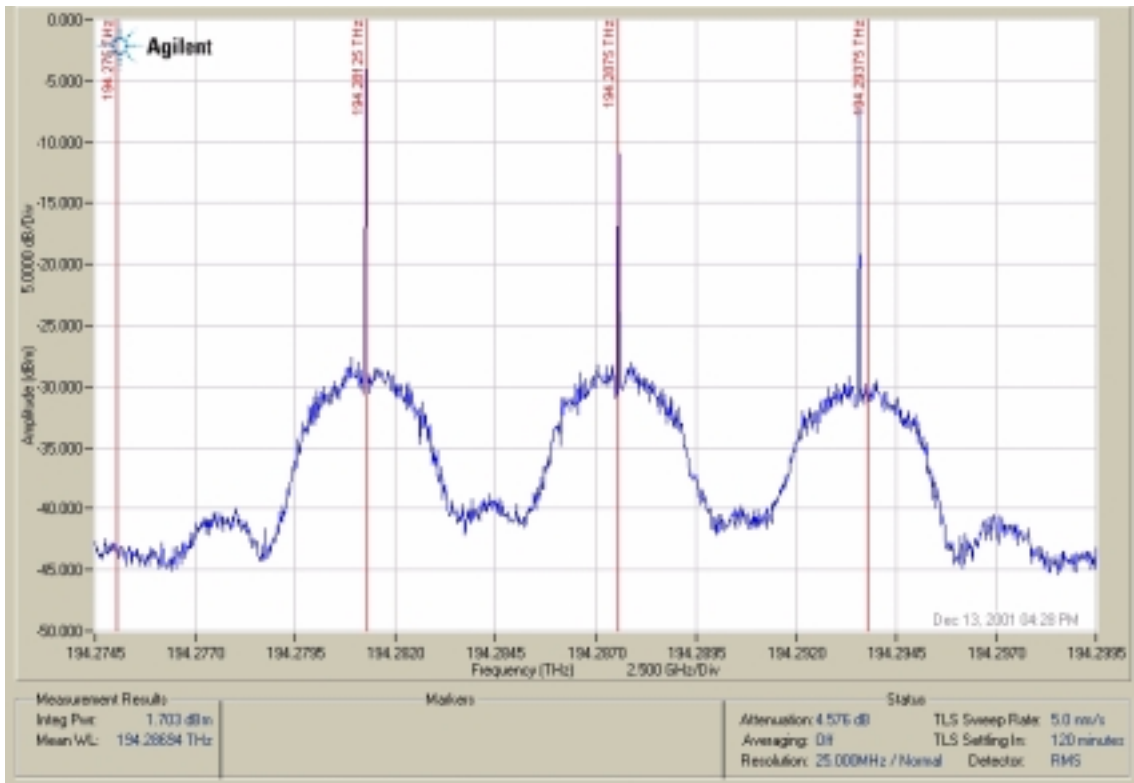

Figure 3-12. Aligning Signals with the ITU Grid

Modulated Narrowband Laser Responses

When chirp free modulation techniques such as Mach-Zehnder LiNbO₃, the true $(\sin(x)/x)^2$ power spectrum is revealed.

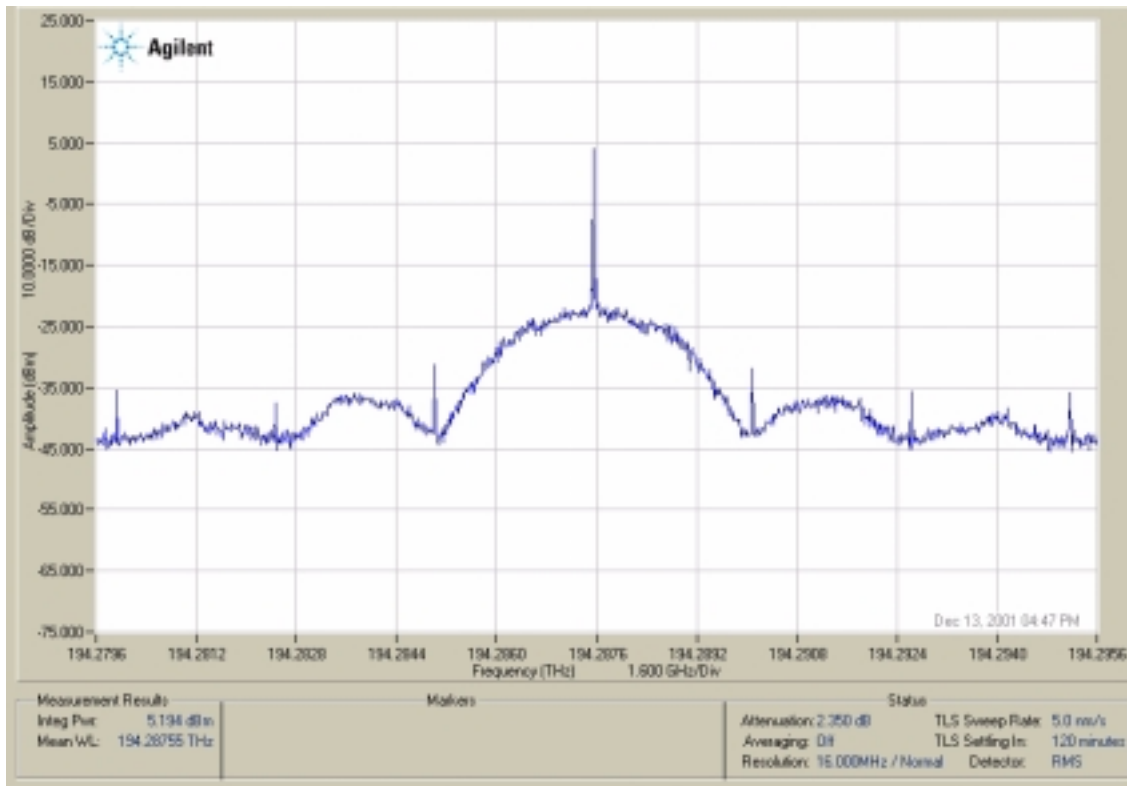

Figure 3-13. Narrowband Laser Modulated with 2.5 Gb/sec NRZ

File Menu	4-3
View Menu	4-10
Setup Menu	4-29
Measure Menu	4-39
System Menu	4-41
Application Toolbar	4-43
Measurement Results Area	4-52

Function Reference

Function Reference

The following section provides descriptions of each software function. Each function is documented in the order that it appears in the Applications menu bar. Refer to [“Using the HRS” on page 3-1](#) for complete information on how to make timely, accurate measurements on your device under test (DUT).

This section assumes that you have a working knowledge of an MS Windows-based computer and its operating conventions. It also assumes you know how to open, save, and close files. For help with any of these techniques, please see your MS Windows® documentation.

File Menu

The File menu is used to save, recall, and print data.

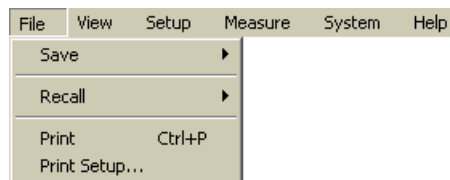

File Menu

Save

The Save menu accesses a submenu to save the trace data, instrument state, and screen images.

Save Trace Data

The Save Trace Data dialog box saves the current data trace points. This file is saved as an ASCII text file with a .trc extension. The file can be stored locally on the instrument, on a floppy disk, or on a network mounted drive (if configured). The data is comma separated and can be read directly into popular spreadsheets and analysis packages such as Matlab® or Excel®.

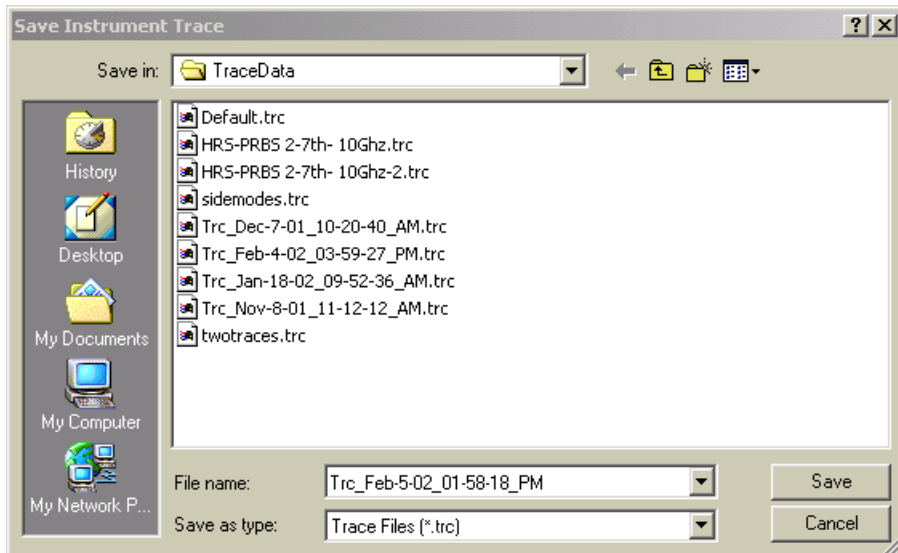

The Save Trace Data dialog box can be accessed from the File > Save menu.

Save Instrument State



The Save Instrument State dialog box saves the current instrument settings and trace data points. The measurement data is saved with a .sta extension. When this file is recalled using File > Recall, all the measurement parameters will be set to the same values as when the file was saved.

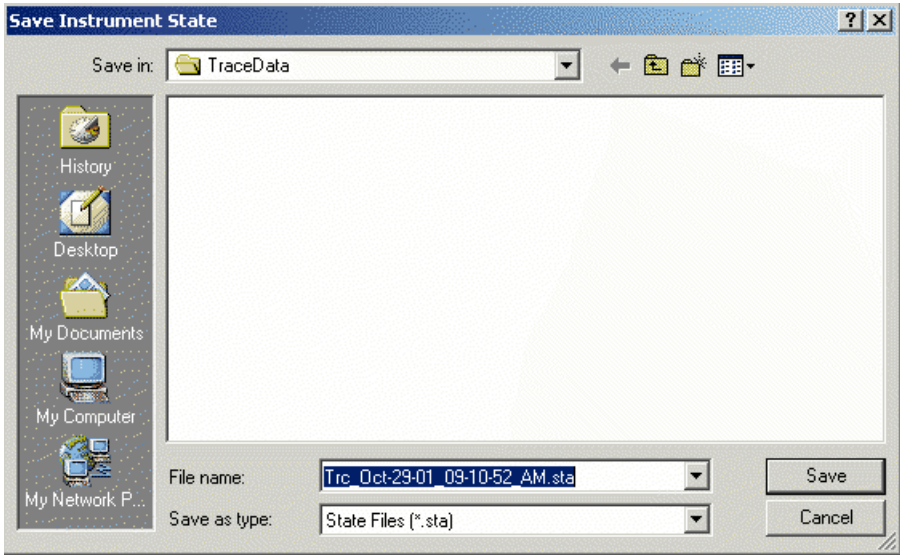

The Save Instrument State dialog box can be accessed from the icon on the toolbar or from the File > Save menu.

Tip: Use Save Trace Data to import the measurement settings and data points to another application, for example, Microsoft Excel. Use Save Instrument State to recall the settings into the application at a later time.

File Menu**Save Screen Image**

The Save Screen Image dialog box is used to save the display graticule and status area to either a bitmap file (.bmp) or JPEG (.jpg). Bitmap and .jpg files can be opened by image processing applications such as Windows Explorer® and Netscape®. The files can also be imported into Microsoft Word® documents. Bitmap files are large in file size (for example, 1.5 MB) but have better resolution than a JPEG file. JPEG files are much smaller (for example, 1 to 2 kB), but have a lower resolution.

Tip: Save the image as a jpg file when saving to a floppy disk, or when storage size is an issue.

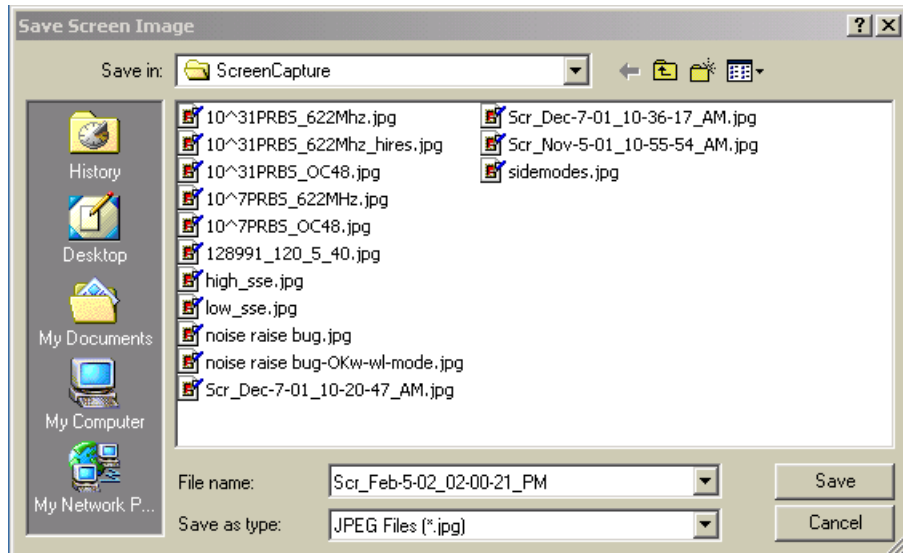

Recall Instrument State

The Recall Instrument State dialog box is used to open previously saved instrument state and trace data. When an instrument state file is recalled, the measurement parameters will be restored to the same state as when the file was saved.

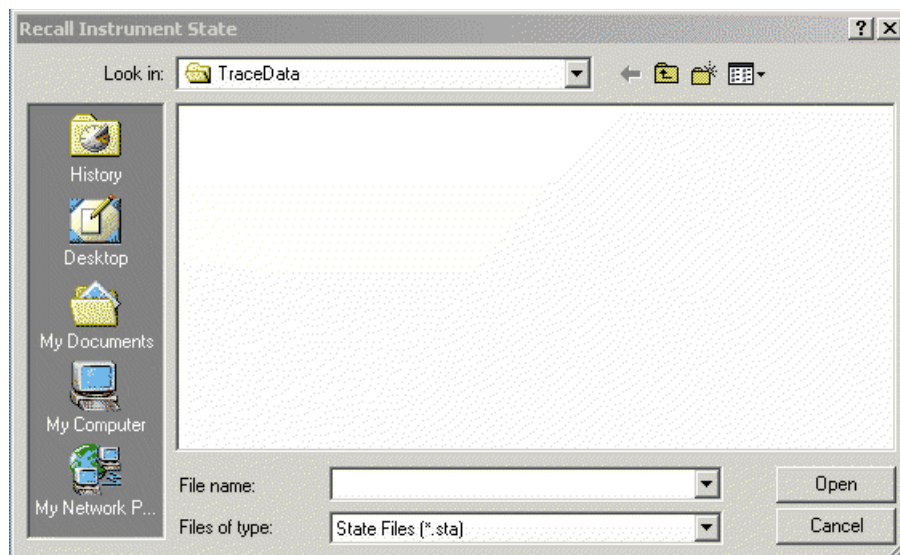

Print



The Print command prints a copy of the display graticule and status area to the printer selected in the Print Setup dialog box.

The Print command can be accessed from the icon on the toolbar or from the File > Print menu.

Print Setup

The Print Setup dialog box is used to specify page setup options on the printer supplied with the 83453A system.

CAUTION

Agilent Technologies does not recommend installing any additional software on the system controller. Some third party software, including printer drivers, may impair operation.

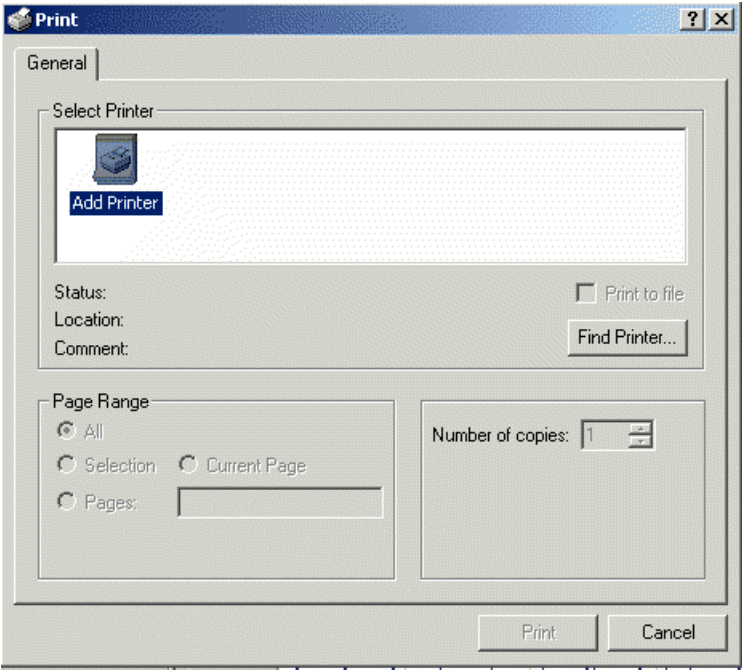

View Menu

View Menu

The View menu is used to access the Wavelength, Amplitude, and Marker setup panels which are used to specify the parameters for your measurement. The Message History and Data Logging Watch windows are used to display these events as they occur. The View menu also accesses the Zoom functions of the display.

Tip: All of these functions, with the exception of the Data Logging Watch window, can also be accessed from either the toolbar or from the Setup panel.

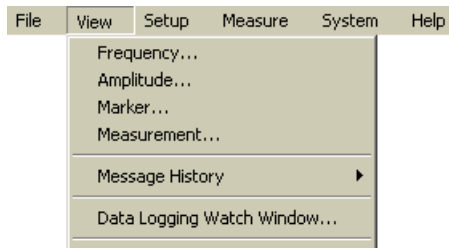

Frequency/Wavelength

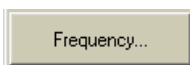

The Frequency/Wavelength button accesses the functions that specify the measurement span. The label of this button changes depending on what is selected for the X-Axis units. The default setting is Frequency.

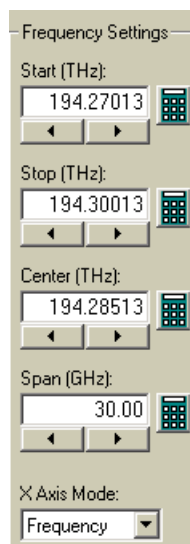

Start (nm or THz)

Sets the start wavelength or frequency, whichever is specified for the X-axis. The center wavelength or span are adjusted so that:

$$Start = Center - \frac{Span}{2}$$

Click on the Start box or the calculator icon to select the desired value. Either the keyboard or touchscreen display can be used to enter the values.

Stop (nm or THz)

Sets the stop wavelength or frequency, whichever is specified for the X-axis. The center wavelength or span are adjusted so that:

$$Stop = Center + \frac{Span}{2}$$

Click on the Stop box or the calculator icon to select the desired value. Either the keyboard or touchscreen display can be used to enter the values.

Center (nm or THz)

Sets the center wavelength or frequency while the span remains constant. The center wavelength and the start and stop wavelength settings are related as follows:

$$Center\ Wavelength = \frac{stop\ wavelength + start\ wavelength}{2}$$

Click on the Center box or the calculator icon to select the desired value. Either the keyboard or touchscreen display can be used to enter the values.

Span (pm or GHz)

Defines the wavelength measurement range for viewing the spectrum.

View Menu

The span is set symmetrically about the center wavelength or frequency, whichever is selected for the X-axis. The resolution of the wavelength readout decreases as the span setting increases. The minimum span setting is 0.1 pm (or 0.01 GHz). For Hi-Resolution mode, the maximum span setting is 100 pm.

Click on the Span box or the calculator icon to select the desired value. Either the keyboard or touchscreen display can be used to enter the values.

The wavelength measurement range can also be set using the Start and Stop wavelength functions.

X-Axis Mode

Allows you to display the horizontal display axis in either wavelength or frequency units. The measurement results will also be displayed in the units selected.

Amplitude

Amplitude...

The Amplitude button accesses the functions to specify the amplitude scaling and detection method used to make a measurement.

Amplitude

Ymax (dBm)
10.000

Scale per Div (dB):
10.0000

Attenuation (dB):
0.000

Detector

RMS

Peak

Averaging

Off

Count:
10

Ymax (dBm)

Specifies the amplitude of the top graticule of the display. The default value is 10 dBm.

Scale per div (dB)

Specifies the dB per division of the amplitude scale. The Preset value is 10 dB per division. Using the step keys will change the value in a 1, 2, 5 sequence.

Attenuation (dB)

Specifies the input attenuation. Attenuation is coupled to the input optical power. The attenuator is used to minimize compression caused by the signal level that is too high in amplitude. The instrument is designed to measure peak power without significant compression. If your peak power during the sweep is above -5 dBm for a source with line width less than 1 MHz, use attenuation to reduce the peak power to -5 dBm.

Click on the Attenuation box or the calculator icon to select the desired value. Either the keyboard or touchscreen display can be used to enter the values. When a new attenuation value is entered, a sweep must be taken to view the effect on the attenuation level.

Maximum safe power is 23 dBm total, average power. All input power, including pump lasers, should be included in estimating total input power.

Detector

Allows you to select either RMS or Peak for the measuring detector in Normal or High resolution mode.

RMS

Uses a standard Root Mean Square function to average all the data taken within a trace bucket. RMS detection is not available in Wide resolution mode.

RMS is the detector mode you should use for most applications. Use RMS when the device has a slowly varying amplitude response over the resolution displayed in the Status area (lower right of the display).

RMS detection measures the mean power between trace points. Therefore, as you decrease span, when measuring a relatively broad signal, the amplitude response measured by the instrument will decrease as the same power is distributed across more trace points. The total integrated power will not change.

Tip: To convert a RMS marker value to power spectral density divide by:

$$\frac{\text{span}}{\# \text{ trace points} - 1}$$

For example, if the RMS marker value is -5 dBm on a 1001 point 1 nm span sweep, then power spectral density is equal to:

$$-5 - 10 \log \frac{1 \text{ nm}}{1001 - 1} = +35 \frac{\text{dBm}}{\text{nm}}$$

Refer to “RMS vs. Peak Detection” on page 3-6 for more information.

Peak

Enables peak detection which displays the maximum signal detected between trace points. Use Peak detection to measure the marker amplitude of devices with narrow line widths.

Tip: Use peak detection when the signal being measured has a linewidth less than the resolution displayed in the Status area (lower right of the display).

Refer to “RMS vs. Peak Detection” on page 3-6 for more information.

Averaging

Performs a trace to trace average using exponential averaging.

Click Count to select the number (N) of measurement sweeps to be averaged. View the averaging progress in the Status area located in the lower right hand corner of the display.

In spans below 12.4 GHz (100 pm), the averaging data can be affected by the system wavelength repeatability.

NOTE

During averaging, measurement parameters such as mean wavelength, integrated power, line width, and so on are computed from the averaged trace.

If any sweep parameter is changed during averaging, for example wavelength span, attenuation level, detection method; averaging will be reset to zero and start incrementing from 1.

Markers...

Markers

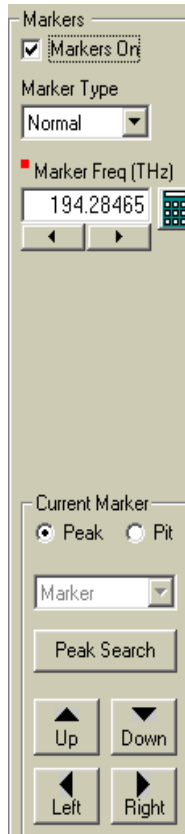

The Marker Setup button accesses the functions to turn on and control markers. For additional information refer to “Using Markers” on page 2-13.

Markers On

Turns the marker functions on or off.

Marker Type

Allows you to select between three types of markers: Normal, Delta, or Bandwidth. Markers On must be selected in order to choose a marker type.

You can view the marker status in the Markers area located at the bottom of the display.

Markers			
■ Marker:	194.28465 THz	-18.281 dBm	Bandwidth: 0.0049 GHz
■ Left:	194.28465 THz	-21.281 dBm	Center: 194.28465 THz
■ Right:	194.28465 THz	-21.281 dBm	BW Setting: -3.0 dB

Markers Information Panel

Normal

Places an active marker on the trace. The normal marker is displayed as a red square. The marker results are displayed in the Information Panel, Marker area.

You can position the marker in three ways:

- Click and drag the marker to a specific location. Notice that the cursor changes into a small hand when the marker is dragged across the display. To use markers, zoom or pan mode must be turned off. Click the Object Select icon (fourth icon from the left) to activate the normal cursor. Depending on the settings that you choose from the Setup > System Setup > Markers tab, the marker will Snap to the Nearest Point, Float, Snap to the Highest Point after Sweep, Snap to the Nearest Peak after Sweep, or Snap to Nearest Point on any Trace.
- Enter a specific frequency/wavelength in the Marker Wvl box.
- Use the marker search buttons in the Current Marker area.

Delta

Activates a Delta marker. The Delta marker is displayed as a black “x”. Either the Delta marker or normal marker can be positioned and the difference is measured and displayed in the Information Panel, Marker area.

You can position the markers in three ways:

- Click and drag the reference marker to measure the difference between the normal marker and the reference marker. Notice that the cursor changes into a small hand when the marker is dragged across the display. To use markers, zoom or pan mode must be turned off. Click the Object Select icon (fourth icon from the left) to activate the normal cursor. Depending on the settings that you choose from the Setup > System Setup > Markers tab, the marker will Snap to the Nearest Point, Float, Snap to the Highest Point after Sweep, Snap to the Nearest Peak after Sweep, or Snap to Nearest Point on any Trace.
- Enter a specific value in either the Marker Wvl, Ref Mkr Wvl, or Delta Wvl boxes.
- Use the marker search buttons in the Current Marker area to move either the Delta Marker or the Normal Marker.

View Menu**Bandwidth**

Measures the spectral width of a signal. Enter the amplitude value in the BW Setting box. The marker results are displayed in the Information Panel, Marker area. For example, selecting -3 dB will calculate the bandwidth 3 dB down from the highest value of the signal. Entering a negative value finds the passband, entering a positive value finds a notch.

You can position the markers in three ways:

- Click and drag the normal marker to a specific location. The normal marker is the centering point for the bandwidth measurement. Notice that the cursor changes into a small hand when the marker is dragged across the display. To use markers, zoom or pan mode must be turned off. Click the Object Select icon (fourth icon from the left) to activate the normal cursor.
- Enter a specific value in the Marker Wvl box.
- Use the marker search buttons in the Current Marker area.

Current Marker Area

Allows you to move the active marker for the selected Marker Type (that is, Normal, Delta, or Bandwidth) to either the peaks or pits of the trace.

Either the normal or reference marker can be selected as the active marker.

Peak places the active marker on a peak of the trace which meets the excursion criteria. Refer to [“Peak/Pit Excursion \(dB\)” on page 4-34](#). Use the marker toolbar to navigate to the desired peak of the trace.

Pit places the active marker on a local minimum of a trace which meets the excursion criteria. Refer to [“Peak/Pit Excursion \(dB\)” on page 4-34](#). Use the marker toolbar to navigate to the desired pit of the trace.

Search places the active marker on the highest or lowest point, that is peak or pit depending of what is selected in the Current Marker area.

Up places the active marker at the next highest peak or pit in amplitude up from the current marker position.

Down places the active marker on the next highest peak or pit in amplitude down from the current marker position.

Left places the active marker to the next peak or pit left of the current marker position.

Right places the active marker to the next peak or pit right of the current marker position.

Measurement

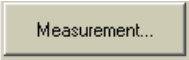

***Note:** Linewidth or spectral width measurements are not available in Peak detection or Hi Resolution modes.*

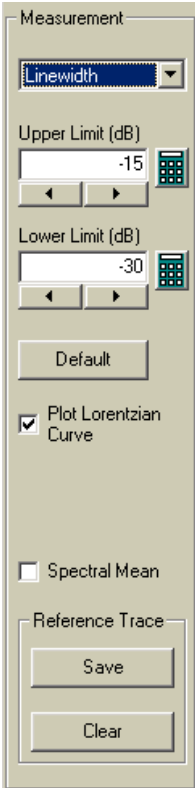

The HRS software includes the ability to model the spectral waveform as either Gaussian or Lorentzian functions. Once you have taken a sweep and centered the signal on the display, press the Measurement button and select either Linewidth (to model a Lorentzian waveform) or Spectral Mean (to model a Gaussian waveform).

The Measurement button accesses the parameters to make either a linewidth or a spectral width measurement.

Most lasers do not strictly follow a Lorentzian curve shape across the entire response. For example, the peak of the response will be Gaussian and any side modes force deviation from Lorentzian. As such, the instrument allows you to specify which portion of the curve to include in the curve fit. You should only include points that clearly follow a Lorentzian shape. Refer to [“Measuring Line Width of a Laser”](#) on page 3-18

Linewidth

Laser spectral broadening is dominantly caused by phase noise and frequency chirp. Broadening due to phase noise is characterized by a Lorentzian distribution.

$$P(\lambda) = \frac{P_{total}}{\left(\frac{LW}{2} \times \pi\right)} \times \frac{1}{1 + \left(\frac{\lambda - \lambda_{mean}}{(LW)/2}\right)^2}$$

Where $P(\lambda)$ is the signal power at wavelength λ .

P_{total} is the total power

LW is the linewidth

λ_{mean} is the mean wavelength, which represents the center of mass of the trace points. The power and wavelength of each trace point are used to calculate the mean wavelength.

The HRS determines linewidth by computing a value for linewidth for each data point, within a specified region and averaging them.

Most lasers do not strictly follow a Lorentzian curve shape across the entire response. For example, the peak of the response will be Gaussian and any side modes force deviation from Lorentzian. As such, the instrument allows you to specify which portion of the curve to include in the curve fit. You should only include points that clearly follow a Lorentzian shape. [Refer to “Measuring Line Width of a Laser” on page 3-18.](#) The results of the measurement are displayed in the Information panel (located at bottom of the display).

Upper Limit dB allows you to set the upper linewidth limit for measurement. You can either enter a value in the box, or click and drag the line to the desired amplitude. The values set are relative to the peak of the signal.

Lower Limit dB allows you to set the lower linewidth limit for measurement. You can either enter a value in the box, or click and drag the line to the desired amplitude. The values set are relative to the peak of the signal.

Default returns the limits to their default values.

Plot Lorentzian Curve

Plots the Lorentzian curve on the display. A Lorentzian curve is a statistical curve based on the total power, power distribution, and mean wavelength. Displaying the Lorentzian curve will assist you in placing the upper and lower linewidth markers at the point where the signal best matches the Lorentzian curve.

Only displayed values are used in the calculation. If you zoom in without taking a new sweep, the curve fit will only use displayed values between the red lines.

Tip: If a limit line is moved, a new linewidth is calculated and a new Lorentzian curve is displayed. Once you have obtained a measured trace, you can adjust the limit lines as needed to obtain the best fit.

Spectral Width

Many lasers don't follow a Lorentzian shape, and any modulated laser will tend towards a Gaussian shape. As such, this function is provided as an alternative to Lorentzian: it fits the trace to a Gaussian curve shape. All displayed trace values are used in the curve fit. The results are displayed in the information panel.

By calculating the standard deviation (σ) we can model the waveform as Gaussian.

$$P(\lambda) = (P_{peak} \times TS / (\text{sqrt}(2 \times \pi) \times \sigma) \times \text{Exp}(\lambda - \lambda_{mean})^2) / (2\sigma^2)$$

where:

TS is the trace point separation.

P_{peak} is the peak power of the waveform.

λ_{mean} is mean wavelength, which represents the center of mass of the trace points. The power and wavelength of each trace point are used to calculate the mean wavelength.

Sigma (σ) is the RMS value of the spectral width of the trace points based on a Gaussian distribution.

$$\sigma = \sqrt{\sum_{i=1}^n \frac{P_i}{P_o} (\lambda_i - \bar{\lambda})^2}$$

where:

$\bar{\lambda}$ is mean wavelength as defined above

λ_i is the wavelength of a single trace point

P_i is the power of a single trace point

P_o is integrated power, which is the summation of the power at each trace point.

The linewidth displayed in the Measurement Results area (bottom of the display) describes the spectral width of the half-power points assuming a continuous, Gaussian power distribution. The half-power points are those where the power spectral density is one-half that of the peak amplitude of the computed Gaussian curve.

$$\text{Linewidth}=2.335\sigma$$

Spectral Mean

Displays a green square at the mean wavelength value.

Plot Spectral Width

Displays the Gaussian curve for the response.

Reference Trace

When Save is selected, the current trace is stored on the display. You can then compare the stored trace against real time data (that is, an active trace). The stored trace color is purple and the active trace is blue. When Clear is selected, the stored trace is removed from the display.

Message History

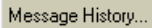
A rectangular button with a light gray background and a thin black border. The text "Message History..." is centered on the button in a small, black, sans-serif font.

Show Messages

Opens the Message History window and displays a history of all instrument errors and messages with the time the event occurred.

Export

Allows you to export the contents of Message History to a file.

Clear Messages

Clears the Message History Log.

Data Logging Watch Window

Opens a window that displays measurement data as it is logged into the data collection file. This feature is useful for monitoring drift or signal variation over time. Refer to “Data Logging” on page 4-30 for more information.



Data Logging Watch Window				
Mean WL	Integrated Power	Center WL	Noise Std Dev	Noise Mean
194.28495338649	-58.0842971801758	194.285129520081	1.45475268579375	-88.2532758563893
Mkr Peak Amp	Mkr Peak Wvl	Delta Mkr Peak Amp	Delta Mkr Peak Wvl	
-84.0206461580846	194.284619520085	MKR OFF	MKR OFF	

Fit to Window



Takes the existing trace and fits the display (or window) around it. This function is useful after using the zoom functions. Take a sweep (Single or Continuous) to update the Measurement Results data.

The Fit to Window command can be accessed from the icon on the toolbar or from the View > Zoom menu.

Zoom

Accesses the Zoom functions used to zoom in on a particular portion of the display. Refer to “Using the Zoom Functions” on page 2-8 for more information.

Full Zoom



Reduces both the wavelength/frequency span and the amplitude range on the display. Therefore, the zoomed-in area expands to fill the entire display. By zooming in on an area and taking a sweep, higher resolution can be achieved.

To zoom in on a portion of the trace, select the toolbar’s Full Zoom icon. Next, click and drag to draw a rectangle on the desired portion of the trace. If you make an error while zooming in, select the undo icon to return to the last display setting.

Full Zoom is accessed from the icon on the toolbar or from the View > Zoom menu.

Amplitude Zoom



Reduces the amplitude range on the display. Therefore, the zoomed-in amplitude area expands to fill the entire display. By zooming in on an area and taking a sweep, higher amplitude resolution can be achieved.

To zoom in on a portion of the trace, select the toolbar’s Amplitude Zoom icon. Next, click and drag to draw a rectangle on the desired amplitude portion of the trace. If you make an error while zooming in, select the undo icon to return to the last display setting.

Amplitude Zoom is accessed from the icon on the toolbar or from the View > Zoom menu.

Wavelength Zoom



Reduces the wavelength/frequency span on the display. Therefore, the zoomed-in wavelength area expands to fill the entire display. By zooming in on an area and taking a sweep, higher wavelength resolution can be achieved.

To zoom in on a portion of the trace, select the toolbar's Wavelength Zoom icon. Next, click and drag to draw a rectangle on the desired wavelength portion of the trace. If you make an error while zooming in, click on the undo icon to return to the last display setting.

Wavelength Zoom is accessed from the icon on the toolbar or from the View > Zoom menu.

Zoom Out

Increases both the amplitude and wavelength span by 10%. Click the Zoom Out menu item to activate, then click on the display to zoom out from that area. If the instrument is in Single Sweep mode, you must take a sweep to update the display.

Tip: Hold down the mouse or your finger for repeated zooms. The repeated zooms occur until the mouse or your finger are lifted.

Zoom Out is accessed from the View > Zoom menu.

Zoom In

Decreases both the amplitude and wavelength span by 10%. Click the Zoom In menu item to activate, then click on the desired portion of the display to zoom in on that area. If the instrument is in Single Sweep mode, you must take a sweep to update the display.

Tip: Hold down the mouse or your finger for repeated zooms. The repeated zooms occur until the mouse or your finger are lifted.

Zoom In is accessed from the View > Zoom menu.

View Menu

Pan Zoom



Moves the entire trace on the display with the motion of the mouse pointer. Click the Pan Zoom icon and then click on the display.

This function is useful when you zoom in on a portion of the trace, and need to quickly view another portion.

Pan Zoom is accessed from the icon on the toolbar or from the View > Zoom menu.

Undo Zoom



Reverses the last zoom/pan function one at a time. Undo Zoom returns to the previous window coordinates, but does not retrieve previous trace data.

Undo Zoom is accessed from the icon on the toolbar or from the View > Zoom menu.

The HRS software keeps a circular queue of all previous window coordinates used, from startup to a maximum number of 100.

Object Select



Turns off the currently active zoom or pan function and allows you to select and move markers, if markers are turned on.

Object Select is accessed from the toolbar or from the View menu.

Setup Menu

The Setup menu is used to define the parameters used for the measurement.

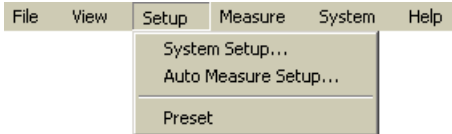

System Settings

The System Settings panel is used to define the behavior of the data logging, state settings, markers, ITU grid, and display functions.

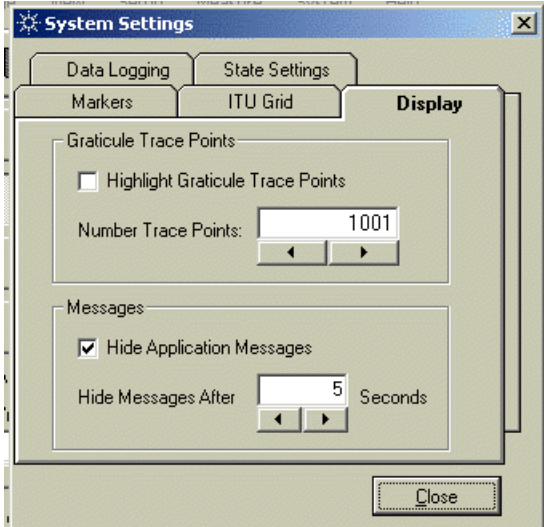

Setup Menu**Data Logging**

Data logging is designed for environmental and manufacturing testing where it is useful to collect measurement data over time. When selected, the following information is saved to a file with data separated by commas. The instrument chooses the log file name using one log file per day.

Tip: To view data as it is being collected, select View > Data Logging Watch Window.

Mean Wavelength represents the center of mass of the displayed trace points. The power and wavelength of each trace point are used to calculate the mean wavelength.

$$\text{Mean Wavelength} = \sum_{i=1}^n \frac{P_i}{P_o} \lambda_i$$

where:

λ_i is the offset wavelength of a single trace point from center wavelength

P_i is the power of a single trace point, in watts

P_o is integrated power as defined below

Integrated Power is the summation of the power at each trace point.

$$\text{Integrated Power} = \sum_{i=1}^n P_i$$

where:

P_i is the power of a single trace point, in watts

NOTE

Markers must be on to collect the following marker data. If not on, these fields contain “Mkr Off”.

Mkr Peak Amp is the power level of the normal marker. Use Marker setup to set this to nearest peak or trace maximum at end of each sweep. [Refer to “Markers” on page 4-33.](#)

Mkr Peak WL is the wavelength of the normal marker.

Center Wavelength is the sum of the start and stop wavelength divided by two:

$$\text{CenterWavelength} = \frac{\text{stop wavelength} + \text{start wavelength}}{2}$$

Delta Mkr Peak Amp is the power level of the delta marker. Use Marker setup to sent to nearest peak or trace maximum at the end of sweep. Refer to “Markers” on page 4-33.

Delta Marker Peak Wvl is the wavelength of the delta marker.

Noise Mean uses 100 trace points on the left edge and 100 trace points on the right edge and calculates a mean value to give an indication of the noise level.

Noise Standard Deviation uses the same data set to calculated the standard deviation of noise.

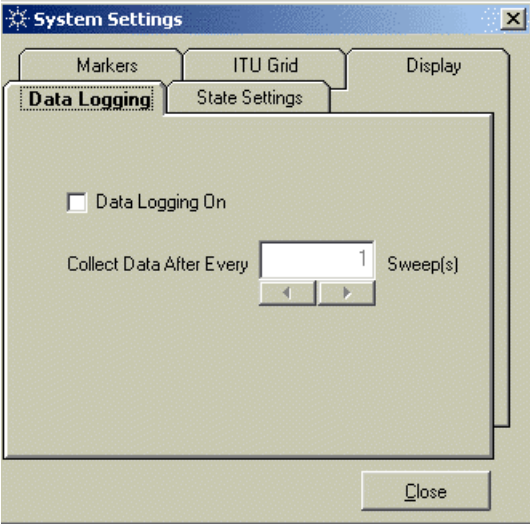

Data Logging On

Collects and stores measurement data in a comma separated text file in d:\HrsUserData\Log\Trc”data and time”.txt. One log file is used per day. Although you may copy or clear the file when the sweep is stopped.

Collect Data After Every x Sweeps

Allows you to specify the number of sweeps taken between data collection. This allows you to sample data over a long time period without creating a large logging file.

Setup Menu

State Settings

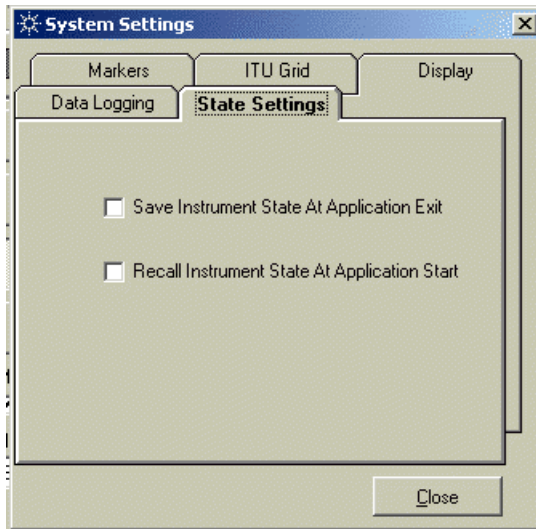

Save Instrument State At Application Exit

Saves the current instrument settings before the application is closed.

Recall Instrument State At Application Start

Restores the instrument settings used when the application was last run.

Markers

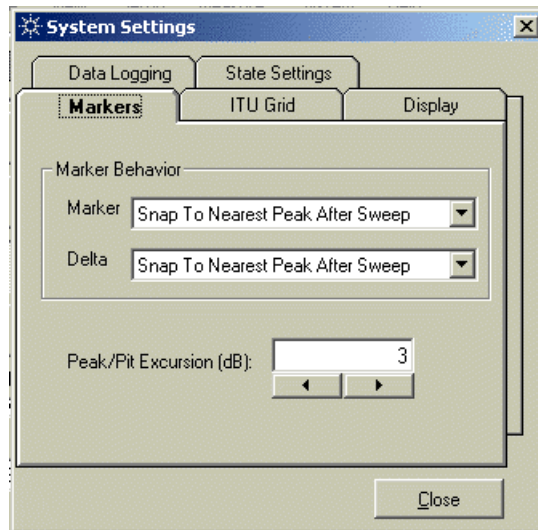

Marker Behavior

Allows you to define the positioning of either the normal and delta marker at the end of each sweep. Markers On (in the Marker Setup panel) must be selected for this function to work.

Snap to Nearest Point moves the marker to the nearest trace point.

Float leaves the marker at the position prior to the previous sweep.

Snap to Highest Point After Sweep tracks the highest point at the end of each sweep.

Snap to Nearest Peak After Sweep tracks the nearest peak signal (as defined by the peak excursion) at the end of each sweep.

Snap to Nearest Point on any Trace tracks the nearest data point on either the active trace or the reference trace. You can turn on the reference trace from the Measurement setup panel.

Tip: Use Data Collection (View > Data Logging Watch Window) to monitor variances in peak amplitude over time.

Setup Menu

Peak/Pit Excursion (dB)

Sets the peak or pit excursion value for the marker search functions. It is used to determine which on screen responses are accepted as discrete spectral responses. To be accepted, each trace peak/pit must rise, and then fall, by at least the excursion value about a given spectral component. Setting the value too high will result in failure to include the smaller response near the noise floor. Setting the value too low will cause all spectral components to be accepted including the second peak of a response with a slight dip.

ITU Grid

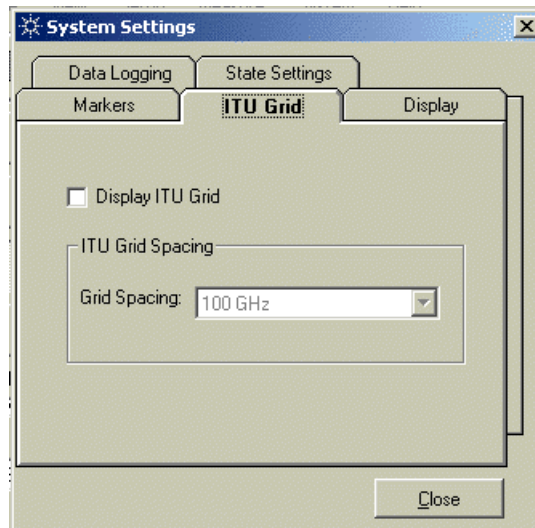

The HRS software includes the ability to overlay a grid of frequencies as defined by the International Telecommunication Union (ITU). The grid is used to align and verify alignment of transmitted signals. The standard uses a frequency grid with a reference of 193.1 THz with channel spacings as integer number of 100 GHz away from the reference. Although not defined by the ITU, the grid can be spaced at 100 GHz, 50 GHz, 25 GHz, 12 GHz, or 6.25 GHz.

The grid colors change depending on which band you are in.

- S-band has pink grid lines

- C-band has red grid lines

- L-band has green grid lines

- U-band has blue grid lines

If Wavelength is selected for the x-axis (Wavelength menu, X Axis Mode), these values are converted from frequency to wavelength.

To activate the ITU grid, select Setup > System Setup > ITU Grid tab.

Display ITU Grid

When selected, superimposes the (ITU) grid on the display.

Grid Spacing

Allows you to select standard ITU grid spacings. Choices are: 6.25 GHz, 12.5 GHz, 25 GHz, 50 GHz, and 100 GHz.

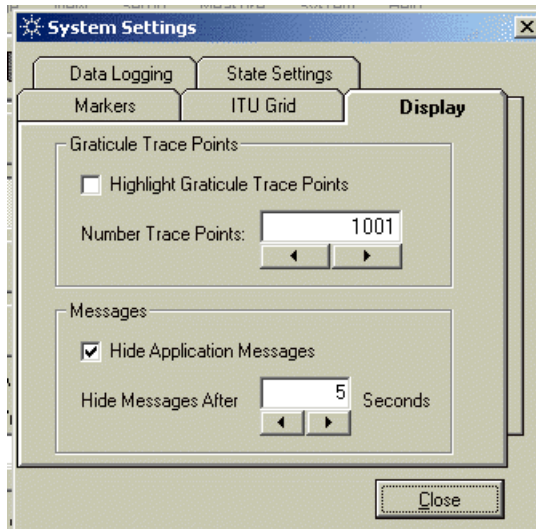
Setup Menu**Display****Highlight Graticule Trace Points**

Displays the trace points on the trace.

Number of Trace Points

Allows you to specify the number of data points used for a measurement. You can specify 301 to 10001 points. The default setting is 1001 trace points.

Hide Application Messages

When selected, displays the system or status message for only the specified time in the Status message area of the display (located at the bottom of the display). When cleared, the message is displayed until a new message is introduced.

Auto Measure Setup

The Auto Measure Setup dialog box allows you to define the start and stop wavelength for automatically locating and measuring the signal of the DUT (Auto Measure). The default start and stop frequency/wavelength settings are 182.8226 THz (1512 nm) to 198.5118 THz (1638 nm) respectively. Refer to “Auto Measure” on page 4-39 for more information.

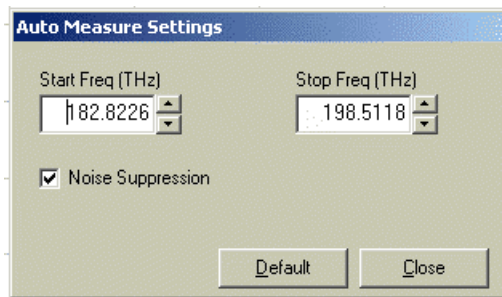

Tip: Limit your measurement span to the boundaries necessary to measure the DUT. Narrower measurement spans will minimize the Auto Measure scan time.

Noise Suppression

The 83453A uses a balanced receiver to reject noise. The optimization balance changes with wavelength and input polarization. When you first connect a signal you should perform noise suppression. Noise suppression is meant to be run with the signal connected. Rerun noise suppression when the signal wavelength changes or the noise floor appears to move.

Modulation or noise on the input signal make most heterodyne systems useless. The HRS employs a balanced mixer instead of a simple coupler and photodiode. The balanced mixer is composed of several optical components and more than one photodiode such that the signal noise is minimized inside the receiver. The optimum mixer balance depends on the input signal wavelength and polarization, so it is necessary to rebalance the receiver frequently. The balance operation is part of the Auto Measure function, and can also be run at any time by selecting System > Operations > Noise Suppression.

Preset

Preset

Resets the instrument to a known state. Selecting preset aborts any current operations.

Table 4-1. Default values

Function	Preset Value	Function	Preset Value
Resolution	Normal	X-Axis Mode	Frequency
Start frequency	193.05 THz	Stop frequency	193.15 THz
Center	193.1 THz	Span	100 GHz
Ymax	10 dBm	Scale per Division	10 dB
Attenuation	0 dB	Detector	RMS
Averaging	Off	Average Count	10
Markers	Off	Peak/Pit Excursion	3 dB
Marker Behavior	Snap to Nearest Peak after Sweep	Delta Marker Behavior	Snap to Nearest Peak after Sweep
Bandwidth Setting	-3 dB	Linewidth Calculation	Off
ITU Grid Spacing	100 GHz	ITU Grid	Off
Highlight Graticule Trace Points	Off	Number of Trace Points	1001
Save Instrument State	Off	Recall Instrument State	Of
Hide Application Messages	On	Hide Messages after	5 seconds

Single Sweep

A small grey rectangular icon with the text "Single Sweep" in white.

Initiates one sweep of the measurement range. Use this function to update the displayed measurement data.

A sweep indicator is located just above the graticule. When the sweep is in progress, a blue bar shows the status of the sweep. The indicator is off when the sweep is complete.

Continuous Sweep

A small grey rectangular icon with the text "Continuous Sweep" in white.

Sweeps the spectrum continuously and updates the measurement data after each sweep. Continuous sweep ensures evenly timed sweeps for a stable display of the current tuning range. Sweeps will continuously repeat as long as the instrument is in continuous sweep mode. To stop the instrument from sweeping, press the Stop icon on the toolbar or select Measure > Stop Sweep.

A sweep indicator is located just above the graticule. When the sweep is in progress, a blue bar shows the status of the sweep. The indicator is off when the sweep is complete.

Stop Sweep



Stops a continuous sweep once the in-progress sweep is completed.

You must stop a continuous sweep prior to initiating any of the System > Operations or before starting an Auto Measure.

System Menu

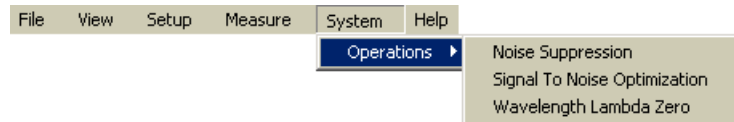

Operations

Noise Suppression

The 83453A uses a balanced receiver to reject noise. The optimization balance changes with wavelength and input polarization. When you first connect a signal you should perform noise suppression. Noise suppression is meant to be run with the signal connected. Rerun noise suppression when the signal wavelength changes or the noise floor appears to move.

Signal to Noise Optimization

Monitors the signal level for saturation. If the DUT signal is above -5 dBm, the attenuator will be adjusted so that the signal will remain in the linear region of the receiver and avoid signal compression.

Wavelength Lambda Zero

Performs a TLS settling. The 83453A relies on the 81640A tunable laser source (TLS) to provide high resolution and dynamic range. This laser has a mechanically tuned cavity that is sensitive to temperature change, requiring the laser to track the internal temperature and occasionally do an internal realignment that takes about 3.5 minutes. The 81640A TLS refers to this operation as “TLS settle.” The HRS uses the temperature inside the laser to predict when the next TLS settle will be needed.

System Menu

A status message, TLS Settling In: xxxm is located at the bottom of the display. The “xxx” refers to the estimated time in minutes before a TLS settle is required. Under normal temperature conditions, the status message may show 120 minutes as the estimate before the next TLS settle is required (120 minutes is the maximum time that the instrument can predict). This status message is updated every minute. It is possible for the status message to continue to read 120 minutes if the ambient temperature remains stable. However, if the ambient temperature changes rapidly, or if the HRS system is turned on before the TLS has been allowed to properly warm-up (approximately 2 hours), then a TLS Settle may be required sooner.

Depending on current ambient temperature conditions, a TLS settle may be executed automatically if the TLS settling indicator reads less than four minutes. For this reason, once the TLS Settling: xxxm message approaches 4 minutes, a TLS settle should be expected at any time. Once a TLS settle has been executed, the front panel will be disabled until it has been completed. This takes approximately 3.5 minutes.

Tip: A TLS Settle can be performed manually at any time. From the menu bar, click System > Operations > Wavelength Lambda Zero.

Application Toolbar

The toolbar gives you one touch access to many of the commonly used functions.

Tip: When you position a cursor over an icon a “tool tip” will be displayed indicating the associated function.

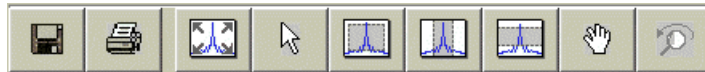

Save Instrument State



The Save Instrument State dialog box saves the current instrument settings and trace data points. The measurement data is saved with a .sta extension. When this file is recalled using File > Recall, all the measurement parameters will be set to the same values as when the file was saved.

The Trace Files Save dialog box can be accessed from the icon on the toolbar or from the File > Save menu.

Tip: Use Save Trace Data to import the measurement settings and data points to another application, for example, Microsoft Excel. Use Save Instrument State to recall the settings into the application at a later time

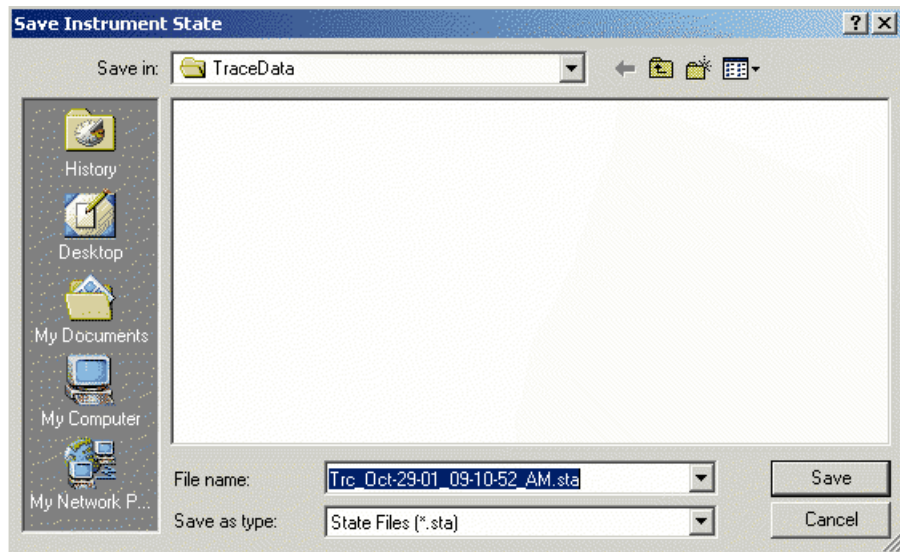

Print



The Print command prints a copy of the display graticule and status area to the printer selected in the Print Setup dialog box.

The Print command can be accessed from the icon on the toolbar or from the File > Print menu.

Fit to Window



Takes the existing trace and fits the display (or window) around it. This function is useful after using the zoom functions. Initiate a sweep (Single or Continuous) to update the Measurement Results data.

The Fit to Window command can be accessed from the icon on the toolbar or from the View > Zoom menu.

Object Select



Turns off the currently active zoom or pan function and allows you to select and move markers, if markers are turned on.

Object Select is accessed from the toolbar or from the View menu.

Full Zoom



Reduces both the wavelength/frequency span and the amplitude range on the display. Therefore, the zoomed-in area expands to fill the entire display. By zooming in on an area, higher resolution can be achieved.

To zoom in on a portion of the trace, select the toolbar's Full Zoom icon. Next, click and drag to draw a rectangle on the desired portion of the trace. If you make an error while zooming in, select the undo icon to return to the last display setting.

Full Zoom is accessed from the icon on the toolbar or from the View > Zoom menu.

Wavelength Zoom



Reduces the wavelength span on the display. Therefore, the zoomed-in wavelength area expands to fill the entire display. By zooming in on an area and taking a sweep, higher wavelength resolution can be achieved.

To zoom in on a portion of the trace, select the toolbar's Wavelength Zoom icon. Next, click and drag to draw a rectangle on the desired wavelength portion of the trace. If you make an error while zooming in, select the undo icon to return to the last display setting.

Wavelength Zoom is accessed from the icon on the toolbar or from the View > Zoom menu.

Amplitude Zoom



Reduces the amplitude range on the display. Therefore, the zoomed-in amplitude area expands to fill the entire display. By zooming in on an area and taking a sweep, higher amplitude resolution can be achieved.

To zoom in on a portion of the trace, select the toolbar's Amplitude Zoom icon. Next, click and drag to draw a rectangle on the desired amplitude portion of the trace. If you make an error while zooming in, select the undo icon to return to the last display setting.

Amplitude Zoom is accessed from the icon on the toolbar or from the View > Zoom menu.

Pan Zoom



Moves the entire trace on the display with the motion of the mouse pointer. Click the Pan Zoom icon and then click on the display.

This function is useful when you zoom in on a portion of the trace, and need to quickly view another portion.

Pan Zoom is accessed from the icon on the toolbar or from the View > Zoom menu.

Undo Zoom



Reverses the last zoom/pan function one at a time. Undo Zoom returns to the previous window coordinates, but does not retrieve previous trace data.

Undo Zoom is accessed from the icon on the toolbar or from the View > Zoom menu.

The HRS software keeps a circular queue of all previous window coordinates used, from startup to a maximum number of 100.

Resolution

Determines the instrument's ability to display two closely spaced signals as two distinct responses. Selections are: Wide, Normal, and High Resolution. Changing from a wide to a higher resolution provides a more accurate measurement but increases the scan time.

Select Wide resolution with any span size for fast sweeps. Wide resolution is designed to quickly find signals over large spans. If span size exceeds 1 nm, wide resolution is selected automatically.

NOTE

Although you may sweep over the full span of the instrument (that is 130 nm), because of the possibility of mode hopping it is recommended to limit the sweep span to less than 50 nm.

For a narrow band sweep, use Normal mode. This provides the most accurate measurements. If measuring an unmodulated laser with less than 5 MHz line width, consider using the Hi-Res mode. The Hi-Res mode uses additional digital filtering to improve resolution to 1 MHz at the expense of speed and amplitude repeatability.

Refer to “Specifications and Regulatory Information” on page 7-1 for specifications for each resolution mode. Refer to “Wide/Normal/HiRes Resolution” on page 3-8 for more information about the resolution modes.

Single Sweep



Single Sweep

Initiates one sweep of the measurement range. Use this function to update the displayed measurement data.

A sweep indicator is located just above the graticule. When the sweep is in progress, a blue bar shows the status of the sweep. The indicator is off when the sweep is complete.

Stop Sweep



Stops a continuous sweep.

Continuous Sweep

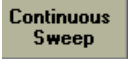

Continuous Sweep

Sweeps the spectrum continuously and updates the measurement data after each sweep. Continuous sweep ensures evenly timed sweeps for a stable display of the current tuning range. Sweeps will continuously repeat as long as the instrument is in continuous sweep mode. To stop the instrument from sweeping, press the Stop icon on the toolbar or select Measure > Stop Sweep.

A sweep indicator is located just above the graticule. When the sweep is in progress, a blue bar shows the status of the sweep. The indicator is off when the sweep is complete.

Auto Measure

Auto Measure

Auto Measure is used to find and measure the largest signal found within the wavelength range specified in the Auto Measure Setup Panel (Setup > Auto Measure Setup). The steps below outline the Auto Measure sequence.

For more detailed information, refer to [“Performing an Auto Measure” on page 2-5](#) and to [“Understanding Auto Measure” on page 2-20](#).

- 1** A wide sweep is taken in Wide resolution mode. The span is by default the full range of the HRS. If the frequency of the DUT is known, auto measure can be set to narrow the span (Setup menu> Auto Measure Setup), thus speeding up the measurement time.
- 2** If a signal is found, a 30 GHz (300 pm) sweep is taken at a 30 MHz resolution bandwidth. The display is adjusted around the signal.
- 3** Another sweep is taken at 16 GHz (150 pm) span and a 1 nm/sec. sweep rate is taken.
- 4** By default, the Noise Suppression procedure will run. This can be disabled in the Auto Measure Setup panel. Noise suppression will take another sweep.
- 5** The signal amplitude is checked for saturation and the attenuator is adjusted for best dynamic range. The signal to noise optimization is run. Refer to [“Signal to Noise Optimization” on page 4-41](#).

Preset

Preset

Resets the instrument to a known state. Selecting preset aborts any current operations.

Table 4-2. Default values

Function	Preset Value	Function	Preset Value
Resolution	Normal	X-Axis Mode	Frequency
Start frequency	193.05 THz	Stop frequency	193.15 THz
Center	193.1 THz	Span	100 GHz
Ymax	10 dBm	Scale per Division	10 dB
Attenuation	0 dB	Detector	RMS
Averaging	Off	Average Count	10
Markers	Off	Peak/Pit Excursion	3 dB
Marker Behavior	Snap to Nearest Peak after Sweep	Delta Marker Behavior	Snap to Nearest Peak after Sweep
Bandwidth Setting	-3 dB	Linewidth Calculation	Off
ITU Grid Spacing	100 GHz	ITU Grid	Off
Highlight Graticule Trace Points	Off	Number of Trace Points	1001
Save Instrument State	Off	Recall Instrument State	Of
Hide Application Messages	On	Hide Messages after	5 seconds

Measurement Results Area

(Located at the bottom of the display.)

Mean Wavelength represents the center of mass of the trace points. The power and wavelength of each trace point are used to calculate the mean wavelength.

$$\text{Mean Wavelength} = \sum_{i=1}^n \frac{P_i}{P_o} \lambda_i$$

where:

λ_i is the offset wavelength of a single trace point from center wavelength

P_i is the power of a single trace point, in watts

P_o is integrated power as defined below

Integrated Power is the summation of the power at each trace point.

$$\text{Integrated Power} = \sum_{i=1}^n P_i$$

where:

P_i is the power of a single trace point, in watts

Linewidth describes the spectral width of the half-power points assuming a continuous, Gaussian power distribution. The half-power points are those where the power spectral density is one-half that of the peak amplitude of the computed Gaussian curve.

$$\text{Linewidth} = 2.335\sigma$$

Spectral Width is calculated using the standard deviation (σ) to model the waveform as Gaussian.

$$P(\lambda) = (P_{peak} \times TS / (\text{sqrt}(2 \times \pi) \times \sigma) \times \text{Exp}(\lambda - \lambda_{mean})^2) / (2\sigma^2)$$

where:

TS is the trace point separation.

P_{peak_i} s the peak power of the waveform.

λ_{mean} is mean wavelength, which represents the center of mass of the trace points. The power and wavelength of each trace point are used to calculate the mean wavelength.

Sigma (σ) is the RMS value of the spectral width of the trace points based on a Gaussian distribution.

$$sigma = \sqrt{\sum_{i=1}^n \frac{P_i}{P_o} (\lambda_i - \bar{\lambda})^2}$$

where:

$\bar{\lambda}$ is mean wavelength as defined above

λ_i is the wavelength of a single trace point

P_i is the power of a single trace point

P_o is integrated power, which is the summation of the power at each trace point.

Function Reference

Measurement Results Area

Overview 5-2
HRS Remote Control DLL 5-3
Using the HRS Remote Control 5-10
HRS Example 5-11

Remote Programming

Overview

The 83453A high resolution spectrometer (HRS) provides the ability to control the HRS Measurement Engine via an ActiveX DLL called HRSRemoteControl. This DLL provides a subset of the capabilities that the HRS user interface performs. Since the control is a DLL, applications can be written in Visual Basic, Visual C++, or any other language that has the capability to integrate a DLL. This chapter describes the methods and events of the control and provides an overview of the example program supplied on the 83453A CD-ROM.

In order to control the HRS remotely, and to access the example programs, the HRS software must be installed on the remote PC. Run the installation package Setup.exe included on the 83453A CD-ROM.

HRS Remote Control DLL

The HRSRemoteControl DLL provides a communication link with the application, which controls the HRS Measurement Engine. The DLL is comprised of a set of Properties, Methods, and Events that together provide a basic set of HRS capabilities.

CAUTION

The HRS user interface and the HRSRemoteControl can both talk to the Measurement Engine at the same time. Commanding both the HRS UI and the HRSRemoteControl at the same time is not advised.

Properties

The following property values can be both assigned and retrieved.

StopWavelength (Double)

Sets the stop or end of sweep position in either wavelength or frequency. The unit value is directly related to the FrequencyBasedSweep property. If FrequencyBasedSweep is true then the units are in THz, if it is False then the units are in nm.

StartWavelength (Double)

Sets the start or beginning of sweep position in either wavelength or frequency. The unit value is directly related to the FrequencyBasedSweep property. If FrequencyBasedSweep is true then the units are in THz, if it is False then the units are in nm.

FrequencyBasedSweep (Boolean)

Sets the StartWavelength and StopWavelength value to frequency or wavelength. When set to True, the start and stop values are in THz. When set to False the start and stop values are in nm.

NumTracePoints (Double)

Sets the number of trace points to be used for a measurement. Increasing the number of trace points increases the measurement accuracy, but also increases the sweep time. The valid range is 301 to 10001.

Resolution (ResolutionType)

Allows you to select one of three resolution settings: HIGH_RES, NORMAL_RES, WIDE_RES.

Host (String)

Specifies the network name of the computer where the HRS will be commanded.

Detector (Detectors)

Specifies the type of detector (RMS or Peak) to be used for the sweep.

Methods

SweepRange (startPosition As Double, stopPosition As Double, FrequencyBasedSweep As Boolean)

Allows the startWavelength, stopWavelength, and the frequencyBasedSweep properties to be assigned all at the same time.

Connect()

Connects the HRSRemoteControl DLL to the Measurement Engine denoted by the Host property.

Disconnect()

Disconnects the HRSRemoteControl from the data sockets. Communication is disabled at this point.

Sweep() As Boolean

Sends a command to the MeasurementEngine to perform a sweep. Sweep performs a check of all the sweep parameters. If an invalid value is found then an error is raised. The Err.Number will correlate to an ErrorValue type (if the DLL has produced the error) and the Err.Description will detail what is wrong. Sweep returns a True if the sweep is sent and a False if it was not. An error is raised if one of the sweep values is invalid.

Important: Make sure that you wrap the Sweep command with an “On Error” to catch any errors thrown.

StopSweep()

Sends a command to the Measurement Engine to cancel the current sweep.

LambdaZeroInProgress() As Boolean

Returns a Boolean value which indicates that the HRS is performing a TLS Lambda Zero.

ShutdownMeasurementEngine()

Sends a command to the MeasurementEngine telling it to shutdown.

CheckAll() As Boolean

Checks all of the sweep settings for the HRSRemoteControl. If an invalid value is found then an error is raised. The Err.Number will correlate to an Error-Value type and the Err.Description will detail what is wrong. CheckAll returns a True when valid and a False if it was not.

Important: Make sure that you wrap the CheckAll command with an “On Error” to catch any errors thrown.

CheckDetectors (ByRef msg As String) As Boolean

Checks to see that the detector is set to a valid value. True is returned if it is valid and False is returned if it is not. A message is returned that describes why the setting is invalid.

CheckNumTracePoints (ByRef msg As String) As Boolean

Checks to see that the number of trace points is valid. True is returned if it is valid and False is returned if it is not. A message is returned that describes why the setting is invalid.

CheckSpan (ByRef msg As String) As Boolean

Checks to see that the sweep span is valid. True is returned if it is valid and False is returned if it is not. A message is returned that describes why the setting is invalid.

CheckStartStop (ByRef msg As String) As Boolean

Checks to see that the startWavelength and stopWavelength values are valid. True is returned if it is valid and False is returned if it is not. A message is returned which describes why the setting is invalid.

CheckResolution (ByRef msg As String) As Boolean

Checks to see that the resolution is set to a valid value. True is returned if it is valid and False is returned if it is not. A message is returned which describes why the setting is invalid.

Enumerated Types

Identifies the various errors which might be raised by the HRSRemoteControl DLL include:

Table 5-3. Error Values

Value	Cause
ERR_SPAN_INVALID	The distance between the start and stop is either too large or too small.
ERR_LAMBDA_ZERO_IN_PROGRESS	Lambda Zero is in progress. Sweeps will not be allowed during Lambda Zero.
ERR_START_STOP_INVALID	The start and/or stop wavelength/frequency are invalid (For example, Out of range).
ERR_NUM_TRACEPOINTS_INVALID	The number of trace points requested is not supported.
ERR_DETECTOR_SETTINGS_INVALID	The detector must be either Peak or RMS
ERR_RESOLUTION_INVALID	There are 3 different resolutions (HIGH_RES, NORMAL_RES, and WIDE_RES). Valid spans are as follows: HIGH_RES for ≤ 100 pm spans. NORMAL_RES for 100 to 1000 pm spans WIDE_RES can be used for ≥ 100 pm spans. Must be used for ≥ 1000 pm spans.

Table 5-4. Resolution Type

Type	Description
HIGH_RES	Must be used for ≤ 100 pm spans.
NORMAL_RES	Used for 100 to 1000 pm spans.
WIDE_RES	Can be used for ≥ 100 pm spans. Must be used for ≥ 1000 pm spans.

Table 5-5. Detectors

Type	Description
RMS	Takes the integrated power of the trace bucket.
Peak	Takes the peak power of the trace point bucket.

Events

LambdaZeroStarted()

This event is triggered when the TLS has started a Lambda Zero.

LambdaZeroFinished()

This event is triggered when the TLS has finished a Lambda Zero.

MeasEngineNotResponding()

Indicates that the Measurement Engine failed to respond after a Connect has been performed. The problem will occur only if the Measurement Engine is not running or cannot respond.

MeasEngineInitialized()

Occurs when a connection has been made to the Measurement Engine and it has responded to a “Are You There?” message.

SocketsConnected()

Indicates that all the data sockets, which are used for communication with the Measurement Engine, have connected successfully. This does not indicate that communication with the MeasurementEngine has been established.

CommandCancelled()

Indicates that the current command executing in the MeasurementEngine has been cancelled.

MessageUpdated (Message As String)

Indicates that a message was received from the HRSRemoteControl DLL. These are informational messages which describe state changes, errors, and so on. These messages are helpful for debugging.

SweepProgressUpdated (Status As Integer)

This event fires while a sweep is in progress. It provides a percentage complete value. This is useful for incrementing a progress bar that shows how much of the sweep the MeasurementEngine has calculated.

- Status As Integer – A value from 1-100 where 100 is the completion of the sweep. The value represents a percentage complete.

Public Event SweepDataUpdated (Data() As Double, xFirst As Double, xInc As Double)

This event is fired when a sweep has completed. Three variables contain data:

- Data() As Double is an array (1 dimensional) of amplitude values.
- XFirst As Double is the x position (wavelength or frequency) of the first data point returned.
- Xinc As Double is the space between each data point

The formula for calculating each data point is:

$X_{position} = x_{First} + x_{Inc} \times i$ where “i” is the datapoint number, i=0 in is the first point.

Using the HRS Remote Control

To command the HRS using the HRSRemoteControl you will need the following:

- HRSRemoteControl DLL

This DLL is required to control the HRS Measurement Engine. Include this ActiveX DLL in your application and create an instance of the CHRSRemoteControl class. For Example:

```
Public WithEvents tHRSRemoteControl As CHRSRemoteControl  
Set tHRSRemoteControl = New CHRSRemoteControl
```

- LWDMeasEngine DLL

This DLL needs to reside on the machine that your application will run from. This DLL needs to be registered.

- System.ini file

This ini file needs to be in the directory where your application is running. It contains system information needed by the HRSRemoteControl DLL. A message box will appear if the file cannot be found.

- An Application

These components need a user interface to run from.

HRS Example

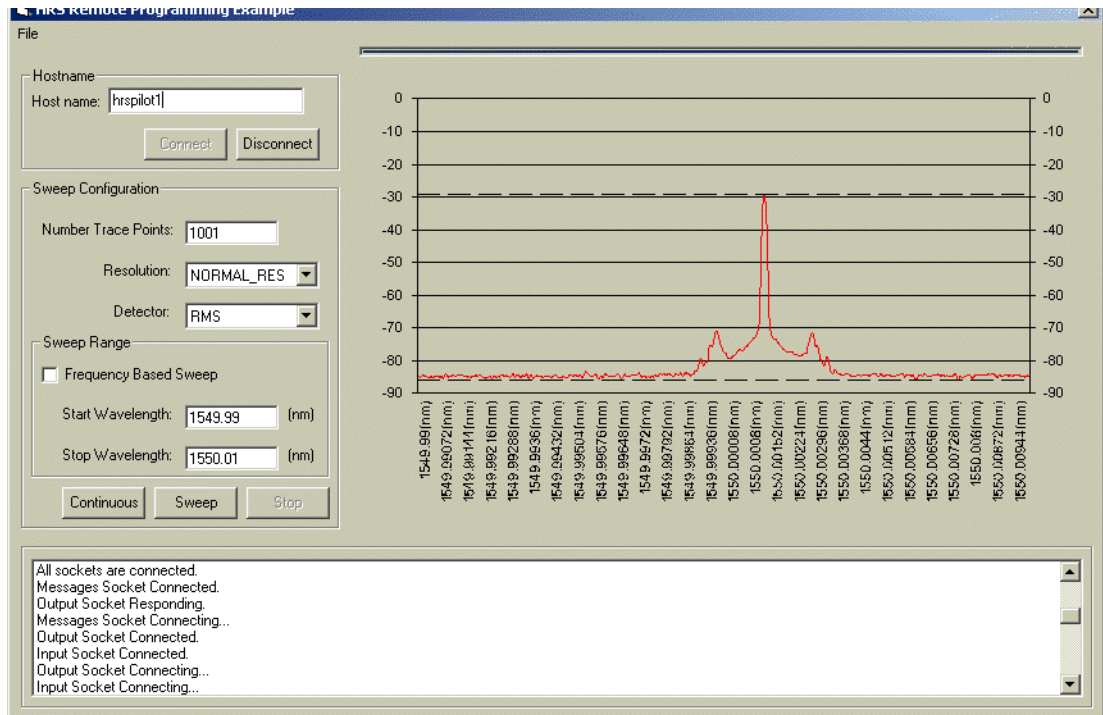

A Visual Basic example is provided with the HRS to show how to use the HRSRemoteControl DLL. The HRS also provides a directory that contains the necessary DLLs. The Example is in "Remote Programming" (C:\Program files\Agilent\High Resolution Spectrometer Mark IRemote Programming). The files needed to run are:

HRS Example

Project:

- HRSExample.vbp
- FrmMain.frm
- FrmMain.frx

Files:

- LWDMeasEngine.Dll
- HRSRemoteControl.dll
- System.ini

Running The Application

To run the application:

- 1** Start the HRS software on the HRS platform.
- 2** Start the HRS Example application.
- 3** Enter the HRS machine name in the hostname text box and then click Connect.

A number of messages should appear in the message area at the bottom of the display describing the state of the application. The sweep buttons should then be enabled for commanding after a successful connection.

- 4** Enter sweep parameters. (Start, Stop and so on.)
- 5** Click Single Sweep or Continuous Sweep.
- 6** Click Disconnect when done.

User Interface

The application user interface is comprised of:

Trace Window (MSChart Control)

Displays the trace data. Note: The MSChart control is extremely slow and unwieldy. This control was used in this example because it comes with VB. A better control is recommended for plotting (such as National Instruments Measurement Studio CWGraph control). This control gets very slow as the number of data points increases.

Message Window

Located at the bottom of the screen, displays messages which come from both the HRSRemoteControl and the example application. It will show state changes and the receipt of events.

Sweep Configuration

This grouping of controls is used to configure the sweep and perform the sweep request.

Hostname

This section connects and disconnects the application to an HRS host machine.

Behavior of the HRSExample

You will note that the HRSExample has the following behavior:

- Command Buttons changes with state. For example the sweep buttons are disabled when the application is not connected. The stop button is only enabled when a sweep is in progress, and so on.
- Sweep Data is plotted immediately. Any time the SweepUpdated event is fired the data is plotted. You will note that the HRS UI and the HRSExample can be connected to the MeasEngine at the same time. Any sweep that the HRS UI performs will be displayed on the HRSExample application.
- Messages describe states changes and events at the bottom of the application.

Key Points

- Include the HRSRemoteControl DLL in Your Project

You will need to add the HRSRemoteControl DLL to your project. Go to the VB menu “Project->References”. Click the “Browse” button and locate and select the HRSRemoteControl DLL.

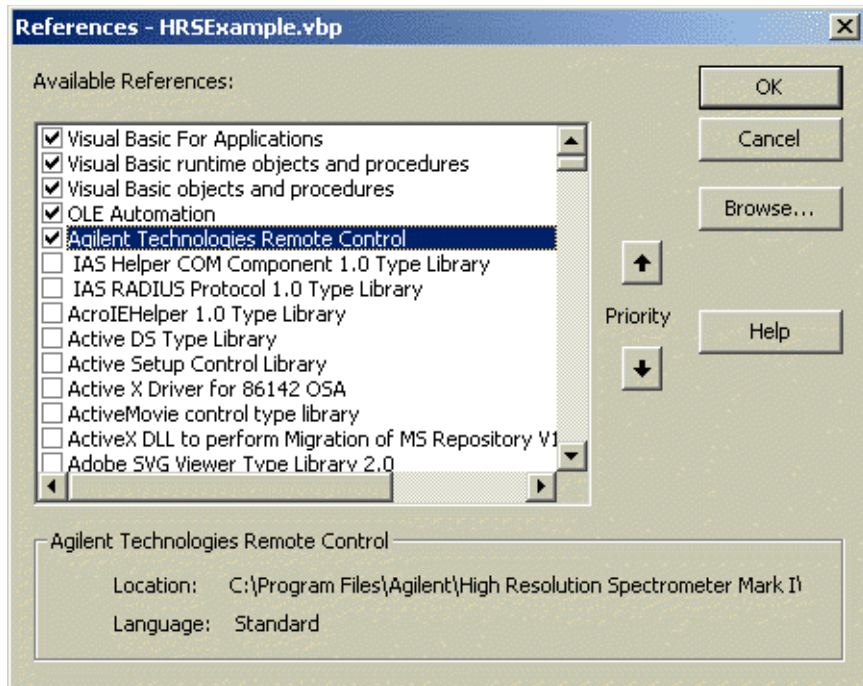

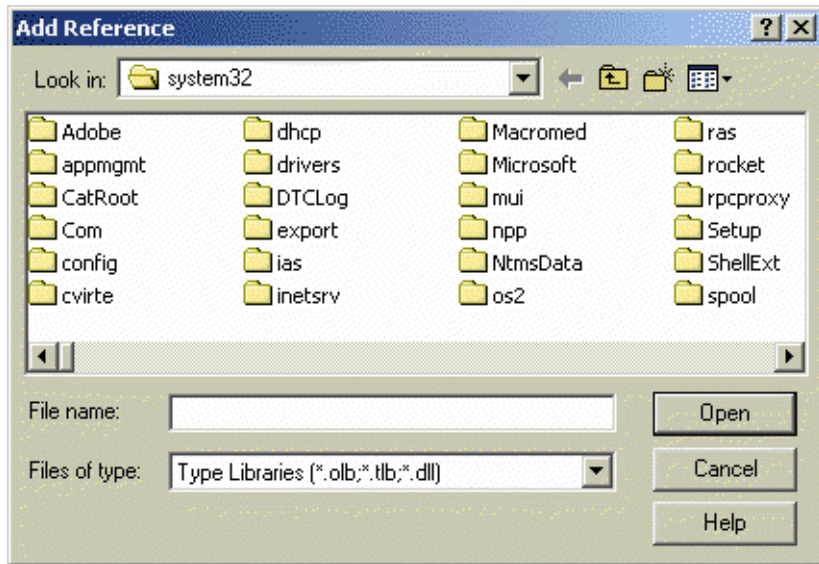

- To use the HRSRemoteControl you will need to create an instance of the CHRRemoteControl Class.

```
Public WithEvents tHRSRemoteControl As CHRRemoteControl  
Set tHRSRemoteControl = New CHRRemoteControl
```

You are ready to start commanding.

- Wrap the Sweep and CheckAll with Error Handlers
These methods will throw exceptions when the sweep configuration is invalid.
- Make sure The Data Socket Server Is Running
Otherwise you will not be able to communicate with the Measurement Engine.

HRS Remote Control Programming Steps – Summary

- 1** Create a project.
- 2** Include the HRSRemoteControl in your project. (Add a reference to the HRSRemoteControl DLL).
- 3** Create an instance of the CHRRemoteControl Class.
- 4** Get Hostname from the User.
- 5** Run the Connect Command.
- 6** Wait for MeasEngineInitialized or MENotResponding Events. This will tell you if you can command or if a problem occurred during the connection.
- 7** Configure the Sweep.
- 8** Sweep (or Check the sweep configuration) – Catch any errors thrown and have the user correct the problems.
- 9** Disconnect.
- 10** Exit.

Troubleshooting the HRS System	6-2
Software Upgrade Procedure	6-12
Hard Drive Backup and Recovery	6-14
Cleaning Connections for Accurate Measurements	6-16
Returning the Instrument for Service	6-26
Agilent Technologies Service Offices	6-28

Maintenance

Troubleshooting the HRS System

Following is a discussion of some basic troubleshooting that can be done to determine if there is a failure of the HRS system. You may wish to run through these checks yourself, or contact the Agilent Test and Measurement Call Center, or your Agilent representative.

To aid in remotely troubleshooting the HRS, each system is shipped with Internet Explorer installed, and a link to a third party server (outside of Agilent) that allows for internet meetings with the HRS system. If you are experiencing problems with your system, an Agilent representative can set up a WebEx meeting, and ask you to join with your HRS system. You can then share the HRS application (and only that application, if you choose) with the representative, and demonstrate what you are seeing on the system. You may allow the Agilent employee to remotely control the HRS application for further troubleshooting, but this is a privilege that you must grant.

The troubleshooting topics include:

- [If the Controller does not boot to MS Windows 2000](#) 6-3
- [If the HRS System Software does not Launch](#) 6-4
- [If the HRS System Software does not Sweep](#) 6-7
- [If the HRS System Displays only Noise](#) 6-8
- [If the HRS System Displays a Weak or Distorted Signal](#) 6-9
- [If the HRS System Noise Floor is Abnormal](#) 6-10
- [If the Touch Screen Display is not Aligning Properly](#) 6-11

Go to the section that describes the behavior you are seeing. If the system does not pass these checks, contact your Agilent Service Representative.

If the Controller does not boot to MS Windows 2000

Controller and Display Errors

The first check is whether MS Windows boots to the flat panel display. If the display does not come up, check the power cable to the display, the controller, and the display cable between the two. For cabling instructions, [refer to “Agilent 83453A Cabling Configuration” on page 1-11](#).

When the correct connections have been verified, reboot the system controller. If the display still does not come up and you have a spare VGA display, try connecting this to the system controller to isolate a display failure.

If the HRS System Software does not Launch

When the PC boots, it will query a user name and password, then automatically launch into the HRS software. If it does not launch, there is a shortcut named HRS Startup on the desktop, or the software can be launched from Start > Programs > Agilent Technologies > High Resolution Spectrometer > HRS Startup.

In launching the HRS Software, the controller attempts to connect to the TLS and the attenuator over GPIB, and prompts each instrument to run a self-test. Error messages will be displayed if the HRS cannot contact the instruments over GPIB, or if there is a self-test failure. There is a 30 minute timeout for contacting the TLS, as the TLS takes at least 12 minutes to fully boot, and may take up to 30 minutes.

If the software does not boot:

- 1 Exit the HRS application start up window.
- 2 Reboot the TLS
- 3 Once the TLS is fully booted, launch the HRS system software from the desktop shortcut.

If the software will still not launch, check the other instruments in the system for errors, ensure that the GPIB addresses are set correctly, and ensure that the 8164A, 81640A, and 8156A are running the specified firmware revision.

Checking the 8164A, 81640A and 8156A for Errors

If there is an error on boot up that does not allow the controller to communicate with the 8164A lightwave measurement system, 81640A tunable laser or 8156A attenuator, an error message may be displayed on the front panel of the instrument.

- If there is an error in the TLS

Check the front panel of the 8164A lightwave measurement system for errors. It is located in the bottom of the system rack. If an alignment or temperature instability error has occurred, the TLS will need to be rebooted. Power it down, and turn the power back on. Wait for the TLS to fully boot before launching the HRS System Software. If the error still exists, see the 8164A lightwave measurement system manual shipped with your HRS System.

- If there is an error in the Optical Attenuator

Check the front panel in the 8156A optical attenuator for errors. It is located directly behind the system's optical input connection, above the work surface. If any errors are displayed, cycle the power on the optical attenuator. Turn the power off, then back on. If the error still persists, see the 8156A manual shipped with your HRS System.

Checking instrument GPIB Addresses

On the 8164A mainframe, press the Local softkey. Press Config > GPIB Address. Ensure that the GPIB address is set to 020.

On the 8156A optical attenuator, press the Local key. Press Syst, and the attenuator will display the current GPIB address "ADDRESS ". Adjust the address with the up and down arrows to set it to 028. Press the Store key.

Checking the 8164A, 81640A and 8156A firmware revisions

The 83453A HRS is specified with an 8164A mainframe of firmware revision 3.03 and higher, and an 81640A tunable laser module of firmware revision 3.00 and higher. If the TLS mainframe or module have been swapped, or the firmware revision has changed to one not supported, the system software will not boot. The TLS mainframe and module firmware upgrade utility, and required firmware revision are shipped on the HRS System. For more information, refer to the Readme file in the C:\Drivers\Support folder.

- To check the firmware revision on the 8164A lightwave measurement system
Press the Local softkey. Press Config > About Mainframe. The mainframe firmware should read V3.03 or higher (on the bottom line).
- To check the firmware revision on the 81640A tunable laser
Press the Local softkey. Press Config > About Modules > Slot 0 > Enter. The Module firmware should read V3.00 or higher.
- To check the firmware revision on the 8156A optical attenuator
Reboot the attenuator, and view the version number shown on the display. It should read "Rev 1.02 10/07/93".

Troubleshooting the HRS System

Running the Data Acquisition Card Self Test

The controller contains two data acquisition cards that accept signals from the custom optical coherent receiver. There is a manufacturer's self test for the controller data acquisition cards. You can run the self test by launching CS_Test from Start > Programs > Gage > Cs_test. Errors with the GaGe cards will be detected in launching this program. When the program has finished launching successfully, close it by going to Controls > Exit.

Changing the Date on the System Controller's Clock

Finally, there can be a conflict in loading the HRS software if the system clock is set to a date earlier than that of the DLLs used to run HRS. This conflict will inhibit the HRS system software from booting. Ensure the clock is set to the current date. To do this, double-click on the clock displayed on the far right of the Windows taskbar (at the bottom of the screen). Adjust the controller date to the current date.

If the HRS System Software does not Sweep

If the HRS system software launches, but will not take a sweep, the first step is to shut down the software, and relaunch it. If this does not solve the problem, reboot the system controller. Next, there will be some checks on the 8164A lightwave measurement system.

If the HRS Software will not Respond

If the HRS system software will not sweep, and the software is not responding, close the HRS program. This can be done by pressing Alt-F4. Relaunch the software through the shortcut on the desktop, or from Start > Programs > Agilent Technologies > High Resolution Spectrometer > HRS Startup.

If the software comes up and will still not sweep, check the trigger cable from the TLS Trig OUT to the PCI card on the rear of the controller. Refer to “Agilent 83453A Cabling Configuration” on page 1-11.

If the HRS Software is Responsive, but will not Sweep

Close the HRS software. Check the TLS and optical attenuator firmware revisions. Reboot the TLS, and allow it to boot fully before relaunching the HRS software.

The 83453A HRS is specified with an 8164A mainframe of firmware revision 3.03 and higher, and an 81640A Tunable Laser Module of firmware revision 3.00 and higher. If the TLS mainframe or module have been swapped, or the firmware revision has changed to one not supported, the system software will not boot. The TLS mainframe and module firmware upgrade utility, and required firmware revision are shipped on the HRS system. For more information, refer to the Readme file in the C:\Drivers\Support folder.

- To check the firmware revision on the 8164A lightwave measurement system
Press the Local softkey. Go to Config > About Mainframe. The mainframe firmware should read V3.03 or higher (on the bottom line).

To check the firmware revision on the 81640A tunable laser

Press the Local softkey. Go to Config > About Modules > Slot 0 > Enter. The Module firmware should read V3.00 or higher.

- To check the firmware revision on the 8156A optical attenuator

Reboot the attenuator, and view the version number as it is shown on the display. It should read “Rev 1.02 10/07/93”.

If the HRS System Displays only Noise

If the HRS system software launches, but displays only noise when a signal is connected to the Optical Input, the first step is to press the Auto Measure button. If no signal is found, shut down the software, and relaunch it. Next, there will be some checks on the 8164A Lightwave Measurement System.

Relaunch the HRS Software

If the HRS system software will not sweep, and is not responding, close the HRS program. This can be done by pressing Alt-F4. Relaunch the software through the shortcut on the desktop, or from Start > Programs > Agilent Technologies > High Resolution Spectrometer > HRS Startup.

Check the Optical Connection

If there is a weak signal, or no signal, thoroughly clean the front panel input connector and adapter sleeve. Refer to [“Cleaning Connections for Accurate Measurements” on page 6-16](#) for explicit cleaning instructions. If there is a fiber optic scope available, visually inspect the input connector.

Check System Component Power, System Connections

- Check the coherent receiver power

Verify that the coherent receiver's power is on. The coherent receiver is located directly underneath the work surface. (Refer to [“Agilent 83453A Cabling Configuration” on page 1-11](#).) A green LED in the lower left-hand corner of the coherent receiver front panel indicates that the it is turned on. If the LED is not lit, check the receiver's power cable.

- Check the Optical Attenuator Enable Light

Ensure that the optical attenuator enable light is on. It is located directly behind the system's optical input connection, above the work surface. There is a green LED indicating that the attenuator is enabled. If this output has been disabled, press the “Enb Dis” button at the lower right hand corner of the front panel buttons.

- Check the BNC and Optical Connections

Refer to “[Agilent 83453A Cabling Configuration](#)” on page 1-11 and ensure that all of the BNC cables are routed correctly. Also, check the optical fiber connections. If an optical connection has been broken (the fiber disconnected from its rightful instrument) the system will need to be recalibrated by Agilent Technologies. Breaking any optical connection voids the system calibration.

If the HRS System Displays a Weak or Distorted Signal

Check the BNC and Optical Connections

Refer to “[Agilent 83453A Cabling Configuration](#)” on page 1-11 and ensure that all of the BNC cables are routed correctly. Also, check the optical fiber connections. If an optical connection has been broken (the fiber disconnected from its rightful instrument) the system will need to be recalibrated by Agilent. Breaking any optical connection voids the system calibration.

Ensure that the TLS outputs are connected correctly. It is required for system performance that the High Power and Low SSE outputs from the TLS are routed correctly to the coherent receiver.

If the HRS System Noise Floor is Abnormal

If the HRS displays a strong signal, but the noise floor display is not what is expected, there are some simple checks that can be done, and some optimizations that can be run.

If the Noise Floor is Chopped

There is a known interaction between the HRS and an input signal with AM modulation and components in the 2 to 5 MHz range. With an input signal of this kind, the HRS noise floor will be chopped.

If the Noise Floor is Clipped

If the noise floor of the HRS is clipped, run the Noise Suppression procedure within the HRS Software.

- Run Noise Suppression from HRS Software

From the menu bar, click System > Operations > Noise Suppression. This procedure will balance two channels in the coherent receiver to optimize the noise floor. If Noise Suppression does not correct for an unusually clipped noise floor, contact Agilent Technologies.

If the Noise Level is Too High

The dynamic range of the HRS System is -50dBm . If attenuation has been added to the signal to allow for a high power input signal, the noise floor will raise by the amount of the attenuation. If, accounting for attenuation, the noise floor is still too high, run the Noise Suppression procedure within the HRS Software.

NOTE

Some signals have a lot of noise. Verify the device with an OSA to make sure that the HRS is not simply reporting the actual input signal characteristics.

Run Noise Suppression from HRS Software

- From the menu bar, click System > Operations > Noise Suppression. This procedure will balance two channels in the coherent receiver to optimize the noise floor. If Noise Suppression does not correct for an unusually clipped noise floor, contact Agilent Technologies.

If the Touch Screen Display is not Aligning Properly

If the display cursor is not lined up with your finger, a calibration of the touch-screen is probably required. An alignment is required whenever you:

- Initially install the touchscreen drivers.
 - Change the display resolution, or change the image size or position.
 - Change the touch monitor our touch screen hardware.
 - Notice the cursor is not lined up with your finger.
- 1** Using the mouse, click Start > Settings > Control Panel > ELO Touchscreen.
 - 2** From the ELO Touchscreen Properties, click the General tab and then Align.
 - 3** Following the on screen prompts to align the cursor with your finger touch.

Software Upgrade Procedure

The following steps describe how to install the latest version of software onto your HRS system.

Installations of the HRS software have to be done in the administrator account. On shipment, the HRS PC controller has the administrator account configured with no password.

- 1 To uninstall the previous versions of the HRS software, click Start > Settings > Control Panel > Add/Remove Programs.
- 2 Underneath Agilent Technologies, highlight High Resolution Spectrometer and click Remove.

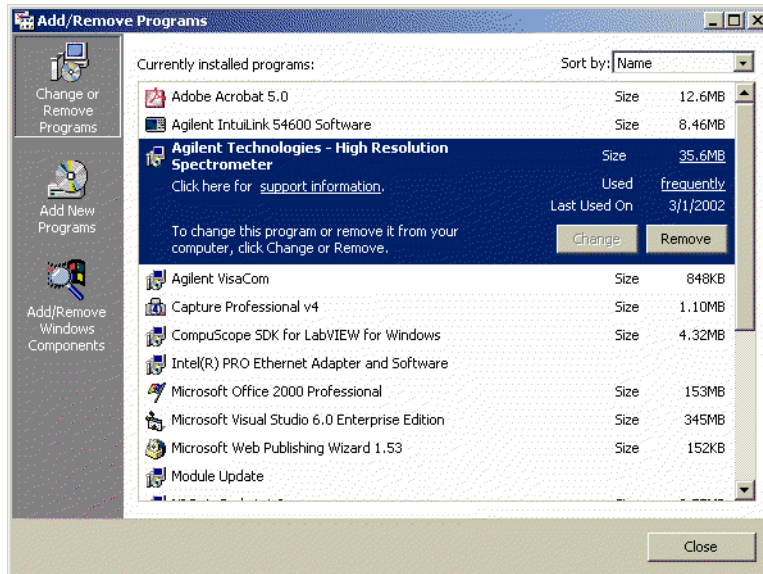

Figure 6-1. Add Remove Programs Dialog

- 3** Updated software can be installed either from the CD-ROM or downloaded from the World Wide Web. Please refer to the HRS product page at www.agilent.com/comms/hrs for more information on software upgrades.
- 4** Run setup.exe and accept the default dialog boxes to complete the software upgrade procedure.

Hard Drive Backup and Recovery

The following procedure is used to back up or restore the operating system on an Agilent Technologies instrument/system running on a MS Windows platform.

NOTE

MS Windows based instruments must have a keyboard attached prior to starting this procedure.

- 1** Insert the System Utility disk (Agilent part number 5011-1306) into the floppy drive.
- 2** Restart the instrument/system controller.
- 3** When the Agilent Technologies System Utilities Screen appears, select from the following options.

- 1. Recover Factory's Backup Image**

This process restores your system to the original, factory-installed operating system and system software. A recovery should be done if MS Windows is corrupted or if you have been instructed to do so by an Agilent service engineer.

- 2. Create User Backup Image**

This process creates a backup image of your system. This process should be done if you have modified the network parameters and/or drivers.

- 3. Recover User Backup Image**

This process restores your system to the user-created backup-image. A recovery should be done if MS Windows is corrupted or if you have been instructed to do so by an Agilent service engineer.

- 4. Exit**

Exits the utility.

Hard Drive Backup and Recovery

- 4** Enter the number associated with the desired action. For example, enter 2 if you want to create a user backup image of your system.
- 5** The procedure will begin. Follow the onscreen instructions to complete the process. The procedure will take approximately 10 to 20 minutes to complete.
- 6** When the process is finished, remove the floppy disk from the disk drive and restart the instrument/system controller.

Cleaning Connections for Accurate Measurements

Today, advances in measurement capabilities make connectors and connection techniques more important than ever. Damage to the connectors on calibration and verification devices, test ports, cables, and other devices can degrade measurement accuracy and damage instruments. Replacing a damaged connector can cost thousands of dollars, not to mention lost time! This expense can be avoided by observing the simple precautions presented in this book. This book also contains a brief list of tips for caring for electrical connectors.

Choosing the Right Connector

A critical but often overlooked factor in making a good lightwave measurement is the selection of the fiber-optic connector. The differences in connector types are mainly in the mechanical assembly that holds the ferrule in position against another identical ferrule. Connectors also vary in the polish, curve, and concentricity of the core within the cladding. Mating one style of cable to another requires an adapter. Agilent Technologies offers adapters for most instruments to allow testing with many different cables. [Figure 6-2 on page 6-17](#) shows the basic components of a typical connectors.

The system tolerance for reflection and insertion loss must be known when selecting a connector from the wide variety of currently available connectors. Some items to consider when selecting a connector are:

- How much insertion loss can be allowed?
- Will the connector need to make multiple connections? Some connectors are better than others, and some are very poor for making repeated connections.
- What is the reflection tolerance? Can the system take reflection degradation?
- Is an instrument-grade connector with a precision core alignment required?
- Is repeatability tolerance for reflection and loss important? Do your specifications take repeatability uncertainty into account?
- Will a connector degrade the return loss too much, or will a fusion splice be required? For example, many DFB lasers cannot operate with reflections from connectors. Often as much as 90 dB isolation is needed.

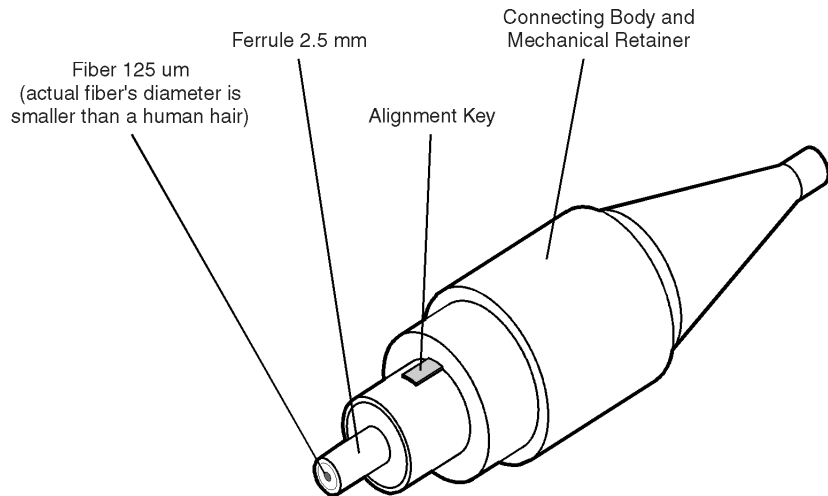
Cleaning Connections for Accurate Measurements**Figure 6-2. Basic components of a connector.**

Over the last few years, the FC/PC style connector has emerged as the most popular connector for fiber-optic applications. While not the highest performing connector, it represents a good compromise between performance, reliability, and cost. If properly maintained and cleaned, this connector can withstand many repeated connections.

However, many instrument specifications require tighter tolerances than most connectors, including the FC/PC style, can deliver. These instruments cannot tolerate connectors with the large non-concentricities of the fiber common with ceramic style ferrules. When tighter alignment is required, Agilent Technologies instruments typically use a connector such as the Diamond HMS-10, which has concentric tolerances within a few tenths of a micron. Agilent Technologies then uses a special universal adapter, which allows other cable types to mate with this precision connector. See [Figure 6-3](#).

**Figure 6-3. Universal adapters to Diamond HMS-10.**

Cleaning Connections for Accurate Measurements

The HMS-10 encases the fiber within a soft nickel silver (Cu/Ni/Zn) center which is surrounded by a tough tungsten carbide casing, as shown in [Figure 6-4](#).

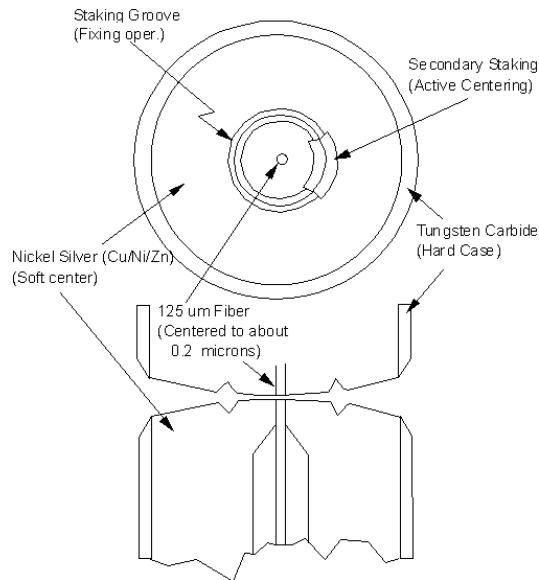

Figure 6-4. Cross-section of the Diamond HMS-10 connector.

The nickel silver allows an active centering process that permits the glass fiber to be moved to the desired position. This process first stakes the soft nickel silver to fix the fiber in a near-center location, then uses a post-active staking to shift the fiber into the desired position within 0.2 μm. This process, plus the keyed axis, allows very precise core-to-core alignments. This connector is found on most Agilent Technologies lightwave instruments.

The soft core, while allowing precise centering, is also the chief liability of the connector. The soft material is easily damaged. Care must be taken to minimize excessive scratching and wear. While minor wear is not a problem if the glass face is not affected, scratches or grit can cause the glass fiber to move out of alignment. Also, if unkeyed connectors are used, the nickel silver can be pushed onto the glass surface. Scratches, fiber movement, or glass contamination will cause loss of signal and increased reflections, resulting in poor return loss.

Inspecting Connectors

Because fiber-optic connectors are susceptible to damage that is not immediately obvious to the naked eye, poor measurements result without the user being aware. Microscopic examination and return loss measurements are the best way to ensure good measurements. Good cleaning practices can help ensure that optimum connector performance is maintained. With glass-to-glass interfaces, any degradation of a ferrule or the end of the fiber, any stray particles, or finger oil can have a significant effect on connector performance. Where many repeat connections are required, use of a connector saver or patch cable is recommended.

[Figure 6-5](#) shows the end of a clean fiber-optic cable. The dark circle in the center of the micrograph is the fiber's 125 μm core and cladding which carries the light. The surrounding area is the soft nickel-silver ferrule. [Figure 6-6](#) shows a dirty fiber end from neglect or perhaps improper cleaning. Material is smeared and ground into the end of the fiber causing light scattering and poor reflection. Not only is the precision polish lost, but this action can grind off the glass face and destroy the connector.

[Figure 6-7](#) shows physical damage to the glass fiber end caused by either repeated connections made without removing loose particles or using improper cleaning tools. When severe, the damage of one connector end can be transferred to another good connector endface that comes in contact with the damaged one. Periodic checks of fiber ends, and replacing connecting cables after many connections is a wise practice.

The cure for these problems is disciplined connector care as described in the following list and in [“Cleaning Connectors” on page 6-23](#).

Use the following guidelines to achieve the best possible performance when making measurements on a fiber-optic system:

- Never use metal or sharp objects to clean a connector and never scrape the connector.
- Avoid matching gel and oils.

Cleaning Connections for Accurate Measurements

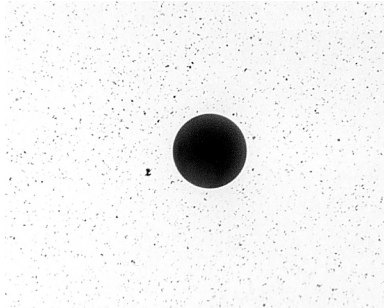

Figure 6-5. Clean, problem-free fiber end and ferrule.

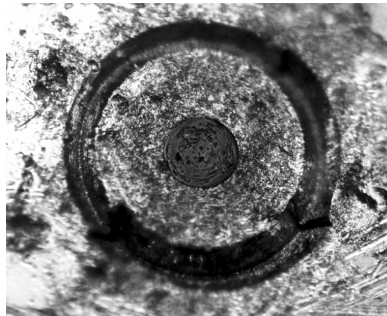

Figure 6-6. Dirty fiber end and ferrule from poor cleaning.



Figure 6-7. Damage from improper cleaning.

Cleaning Connections for Accurate Measurements

While these often work well on first insertion, they are great dirt magnets. The oil or gel grabs and holds grit that is then ground into the end of the fiber. Also, some early gels were designed for use with the FC, non-contacting connectors, using small glass spheres. When used with contacting connectors, these glass balls can scratch and pit the fiber. If an index matching gel or oil must be used, apply it to a freshly cleaned connector, make the measurement, and then immediately clean it off. Never use a gel for longer-term connections and never use it to improve a damaged connector. The gel can mask the extent of damage and continued use of a damaged fiber can transfer damage to the instrument.

- When inserting a fiber-optic cable into a connector, gently insert it in as straight a line as possible. Tipping and inserting at an angle can scrape material off the inside of the connector or even break the inside sleeve of connectors made with ceramic material.
- When inserting a fiber-optic connector into a connector, make sure that the fiber end does not touch the outside of the mating connector or adapter.
- Avoid over tightening connections.

Unlike common electrical connections, tighter is *not* better. The purpose of the connector is to bring two fiber ends together. Once they touch, tightening only causes a greater force to be applied to the delicate fibers. With connectors that have a convex fiber end, the end can be pushed off-axis resulting in misalignment and excessive return loss. Many measurements are actually improved by backing off the connector pressure. Also, if a piece of grit does happen to get by the cleaning procedure, the tighter connection is more likely to damage the glass. Tighten the connectors just until the two fibers touch.

- Keep connectors covered when not in use.
- Use fusion splices on the more permanent critical nodes. Choose the best connector possible. Replace connecting cables regularly. Frequently measure the return loss of the connector to check for degradation, and clean every connector, every time.

All connectors should be treated like the high-quality lens of a good camera. The weak link in instrument and system reliability is often the inappropriate use and care of the connector. Because current connectors are so easy to use, there tends to be reduced vigilance in connector care and cleaning. It takes only one missed cleaning for a piece of grit to permanently damage the glass and ruin the connector.

Cleaning Connections for Accurate Measurements

Measuring insertion loss and return loss

Consistent measurements with your lightwave equipment are a good indication that you have good connections. Since return loss and insertion loss are key factors in determining optical connector performance they can be used to determine connector degradation. A smooth, polished fiber end should produce a good return-loss measurement. The quality of the polish establishes the difference between the “PC” (physical contact) and the “Super PC” connectors. Most connectors today are physical contact which make glass-to-glass connections, therefore it is critical that the area around the glass core be clean and free of scratches. Although the major area of a connector, excluding the glass, may show scratches and wear, if the glass has maintained its polished smoothness, the connector can still provide a good low level return loss connection.

If you test your cables and accessories for insertion loss and return loss upon receipt, and retain the measured data for comparison, you will be able to tell in the future if any degradation has occurred. Typical values are less than 0.5 dB of loss, and sometimes as little as 0.1 dB of loss with high performance connectors. Return loss is a measure of reflection: the less reflection the better (the larger the return loss, the smaller the reflection). The best physically contacting connectors have return losses better than 50 dB, although 30 to 40 dB is more common.

Visual inspection of fiber ends

Visual inspection of fiber ends can be helpful. Contamination or imperfections on the cable end face can be detected as well as cracks or chips in the fiber itself. Use a microscope (100X to 200X magnification) to inspect the entire end face for contamination, raised metal, or dents in the metal as well as any other imperfections. Inspect the fiber for cracks and chips. Visible imperfections not touching the fiber core may not affect performance (unless the imperfections keep the fibers from contacting).

WARNING

Always remove both ends of fiber-optic cables from any instrument, system, or device before visually inspecting the fiber ends. Disable all optical sources before disconnecting fiber-optic cables. Failure to do so may result in permanent injury to your eyes.

Cleaning Connectors

The procedures in this section provide the proper steps for cleaning fiber-optic cables and Agilent Technologies universal adapters. The initial cleaning, using the alcohol as a solvent, gently removes any grit and oil. If a caked-on layer of material is still present, (this can happen if the beryllium-copper sides of the ferrule retainer get scraped and deposited on the end of the fiber during insertion of the cable), a second cleaning should be performed. It is not uncommon for a cable or connector to require more than one cleaning.

CAUTION

Agilent Technologies strongly recommends that index matching compounds *not* be applied to their instruments and accessories. Some compounds, such as gels, may be difficult to remove and can contain damaging particulates. If you think the use of such compounds is necessary, refer to the compound manufacturer for information on application and cleaning procedures.

Table 6-6. Cleaning Accessories

Item	Agilent Part Number
Cotton swabs	8520-0023
Small foam swabs	9300-1223

Table 6-7. Dust Caps Provided with Lightwave Instruments

Item	Agilent Part Number
Laser shutter cap	08145-64521
FC/PC dust cap	08154-44102
Biconic dust cap	08154-44105

Cleaning Connections for Accurate Measurements**Table 6-7. Dust Caps Provided with Lightwave Instruments**

Item	Agilent Part Number
ST dust cover	1401-0291

To clean a non-lensed connector**CAUTION**

Do not use any type of foam swab to clean optical fiber ends. Foam swabs can leave filmy deposits on fiber ends that can degrade performance.

- 1** Apply pure isopropyl alcohol to a clean lint-free cotton swab or lens paper.
Cotton swabs can be used as long as no cotton fibers remain on the fiber end after cleaning.
- 2** Clean the ferrules and other parts of the connector while avoiding the end of the fiber.
- 3** Apply isopropyl alcohol to a new clean lint-free cotton swab or lens paper.
- 4** Clean the fiber end with the swab or lens paper.
Do not scrub during this initial cleaning because grit can be caught in the swab and become a gouging element.
- 5** Immediately dry the fiber end with a clean, dry, lint-free cotton swab or lens paper.
- 6** Blow across the connector end face from a distance of 6 to 8 inches using filtered, dry, compressed air. Aim the compressed air at a shallow angle to the fiber end face.

Nitrogen gas or compressed dust remover can also be used.

CAUTION

Do not shake, tip, or invert compressed air canisters, because this releases particles in the can into the air. Refer to instructions provided on the compressed air canister.

- 7** As soon as the connector is dry, connect or cover it for later use.

If the performance, after the initial cleaning, seems poor try cleaning the connector again. Often a second cleaning will restore proper performance. The second cleaning should be more arduous with a scrubbing action.

To clean an adapter

The fiber-optic input and output connectors on many Agilent Technologies instruments employ a universal adapter such as those shown in the following picture. These adapters allow you to connect the instrument to different types of fiber-optic cables.



Figure 6-8. Universal adapters.

- 1 Apply isopropyl alcohol to a clean foam swab.

Cotton swabs can be used as long as no cotton fibers remain after cleaning. The foam swabs listed in this section's introduction are small enough to fit into adapters.

Although foam swabs can leave filmy deposits, these deposits are very thin, and the risk of other contamination buildup on the inside of adapters greatly outweighs the risk of contamination by foam swabs.

- 2 Clean the adapter with the foam swab.
- 3 Dry the inside of the adapter with a clean, dry, foam swab.
- 4 Blow through the adapter using filtered, dry, compressed air.

Nitrogen gas or compressed dust remover can also be used. Do not shake, tip, or invert compressed air canisters, because this releases particles in the can into the air. Refer to instructions provided on the compressed air canister.

Returning the Instrument for Service

Agilent Technologies aims to maximize the value you receive, while minimizing your risk and problems. We strive to ensure that you get the test and measurement capabilities you paid for and obtain the support you need. Our extensive support resources and services can help you choose the right Agilent products for your applications and apply them successfully. Every instrument and system we sell has a global warranty. Support is normally available for at least five years beyond the production life of the product. Two concepts underlie Agilent's overall support policy: "Our Promise" and "Your Advantage".

Our Promise means your Agilent test and measurement equipment will meet its advertised performance and functionality. When you are choosing new equipment, we will help you with product information, including realistic performance specifications and practical recommendations from experienced test engineers. When you use Agilent equipment, we can verify that it works properly, help with product operation, and provide basic measurement assistance for the use of specified capabilities, at no extra cost upon request. Often, many self-help tools are available.

Your Advantage means that Agilent offers a wide range of additional expert test and measurement services, which you can purchase according to your unique technical business needs. Solve problems efficiently and gain a competitive edge by contracting with us for calibration, extra-cost upgrades, out-of-warranty repairs, and on-site education and training, as well as design, system integration, project management, and other professional engineering services. Experienced Agilent engineers and technicians worldwide can help you maximize your productivity, optimize the return on investment of your Agilent instruments and systems, and obtain dependable measurement accuracy for the life of those products.

On-site Repair

Contact Agilent and a representative will come to inspect the system.

You can get assistance with your test and measurement needs by internet, phone, or fax.

Online assistance: www.agilent.com/find/assist

United States

(tel) 1 800 452 4844

Latin America

(tel) (305) 269 7500

(fax) (305) 269 7599

Canada

(tel) 1 877 894 4414

(fax) (905) 206 4120

Australia

(tel) 1 800 629 485

(fax) (61 3) 9210 5947

Europe

(tel) (31 20) 547 2323

(fax) (31 20) 547 2390

New Zealand

(tel) 0 800 738 378

(fax) 64 4 495 8950

Japan

(tel) (81) 426 56 7832

(fax) (81) 426 56 7840

Asia Pacific

(tel) (852) 3197 7777

(fax) (852) 2506 9284

Agilent Technologies Service Offices

Before returning an instrument for service, call the Agilent Technologies Instrument Support Center at (800) 403-0801, visit the Test and Measurement Web Site at <http://www.agilent.com/find/assist>, or call one of the numbers listed below.

Agilent Technologies Service Numbers

Austria	01/25125-7171
Belgium	32-2-778.37.71
Brazil	(11) 7297-8600
China	86 10 6261 3819
Denmark	45 99 12 88
Finland	358-10-855-2360
France	01.69.82.66.66
Germany	0180/524-6330
India	080-34 35788
Italy	+39 02 9212 2701
Ireland	01 615 8222
Japan	(81)-426-56-7832
Korea	82/2-3770-0419
Mexico	(5) 258-4826
Netherlands	020-547 6463
Norway	22 73 57 59
Russia	+7-095-797-3930

Agilent Technologies Service Numbers

Spain	(34/91) 631 1213
Sweden	08-5064 8700
Switzerland	(01) 735 7200
United Kingdom	01 344 366666
United States and Canada	(800) 403-0801

Maintenance

Agilent Technologies Service Offices

Definition of Terms 7-3
Specifications 7-5
Regulatory Information 7-9
Declaration of Conformity 7-10

Specifications and Regulatory Information

Specifications and Regulatory Information

This chapter contains specifications and characteristics for the Agilent 83453A high resolution spectrometer. For specifications specific to the 81640 and 81680 tunable laser sources refer to the *Tunable Laser Modules User's Guide*.

Definition of Terms

Characteristics and specifications

The distinction between specifications and *characteristics* is described as follows:

- **Specifications** describe warranted performance.
- **Characteristics** provide useful, but nonwarranted and often untested information about the functions and performance of the instrument. *Characteristics are printed in italics.*

Span Range

In the specification tables, span range refers to the span over which the specification is valid.

Frequency/Wavelength

- **Absolute Wavelength Accuracy** is the uncertainty of a frequency/wavelength measurement in absolute terms including relative uncertainties. It is the maximum measurement delta from a known (traceable) reference source on any trace, at any frequency/wavelength position. Errors apply to signals in a single sweep within the specified measurement range.
- **Relative Wavelength Accuracy** is the maximum frequency/wavelength deviation from a known delta between any two signals on any single trace, without regard to any absolute frequency/wavelength value, within the specified measurement range.
- **Wavelength Repeatability** is the maximum frequency/wavelength deviation from sweep-to-sweep while measuring a fixed (that is, unvarying) signal. It is the uncertainty of a frequency/wavelength measurement in which the frequency readout (that is, marker value) of a reference signal is compared to the same, unvarying signal in any subsequent sweep. It is the frequency/wavelength stability over a specified number of sweeps.

Definition of Terms

Amplitude

- **Power Accuracy** is the uncertainty of an amplitude measurement in absolute terms. It is the maximum deviation from a known (traceable) reference source power level after removing the effects of PDL and amplitude repeatability.
- **Amplitude Repeatability**, often called stability, is the maximum amplitude deviation sweep-to-sweep, while measuring a single fixed (that is, unvarying) signal with unchanged instrument settings. It is the uncertainty of an amplitude measurement in which the amplitude of a reference signal is compared to the amplitude of the same signal in any subsequent sweep. It is the stability of marker amplitude readouts displayed over a specified number of sweeps.
- **Scale Fidelity** is the uncertainty in measuring relative differences in amplitude at a single fixed frequency/wavelength and polarization. It is the maximum error in amplitude readout (that is, marker value) at any amplitude, other than at the calibration level, at the same frequency and polarization.
- **Polarization Dependence**, sometimes called PDL for polarization dependent loss, is the maximum deviation in amplitude due to any change in polarization of the signal under test.
- **Displayed Average Noise Level** is the noise floor in the presence of a full-scale input signal, measured at a frequency/wavelength far enough away from the input signal to avoid any residual energy from the input signal. It is the noise floor of the HRS when a signal is present.
- **Dynamic Range** is the ratio of the largest measurable signal to the noise floor at any fixed input attenuation level. It is the difference between the average of the signal level and the average of the noise floor where the noise floor is measured at least 10 pm away from the signal.

Specifications

CAUTION

Agilent Technologies does not recommend installing any additional software on the system controller. Some third party software, including printer drivers, may impair system operation.

Angled Connector Specifications

Wavelength and amplitude accuracy specifications require an angled connector from the source output to the normalized receiver input ports.

Angled contact connectors help you to control return loss. With angled fiber endfaces, reflected light tends to reflect into the cladding, reducing the amount of light that reflects back to the source.

If the contact connector on your TLS is angled, you can only use cables with angled connectors with your TLS. The receiver input has angled connectors and the TLS output has angled connects. Do not connect an flat patch cord to the angle input connector or to the angled TLS connector output.

The angled connector symbol is typically colored green. You should connect straight contact fiber end connectors with neutral sleeves to straight contact connectors and connect angled contact fiber end connectors with green sleeves to angled contact connectors.

Frequency Specifications

Agilent Technologies warrants that the following specifications will be met under the following instrument operating conditions:

- Specifications are defined with frequency terms. For convenience, the delta ranges are provided with wavelength units (in parentheses) assuming a center wavelength of 1550 nm.
- the specified temperature range is 20° to 30° C
- specified over the 1520 to 1620 nm wavelength range only.

Table 7-8. Frequency (Wavelength) Parameters

	High Resolution	Normal Resolution	Wide Resolution
Range	1520 to 1620 nm		
Span Range	250 MHz to 5 GHz (2 pm to 40 pm)	250 MHz 125 GHz (2 pm to 1 nm)	400 MHz to 12.5 THz (4 pm to 50 nm)
Absolute Accuracy^{a, b} with spans ≤12 GHz (100 pm)	± 1.8 GHz (± 15 pm)	± 1.8 GHz (± 15 pm)	± 1.8 GHz (± 15 pm)
Relative Accuracy^c Span ≤5 GHz (≤40 pm) Span >5 GHz to 125 GHz (0.04 nm to 1 nm) Span 1 nm to 50 nm	± 125 MHz (±1 pm) — —	±190 MHz (±1.5 pm) ±400 MHz (±3.2 pm) —	— — ±1.2 GHz (±10 pm) [†]
Repeatability over 5 minutes	± 50 MHz (± 0.4 pm)	±60 MHz (± 0.5 pm)	± 300 MHz (± 2.4 pm)
Nominal Resolution^d	<i>Span/Trace Pts.</i>		
Minimum Resolution^d	1 MHz	15 MHz	20 MHz

a. Verified at 1525 nm, 1550 nm, and 1615 nm.

b. In cases where the marker resolution (which is span/(trace points –1)) exceeds a frequency/wavelength specification, the marker resolution overrides the specification.

c. Assumes constant temperature over measurement interval.

d. Characteristic

Amplitude Specifications

Agilent Technologies warrants that the following specifications will be met under the following operating conditions.

Unless otherwise specified,

- applies in peak detection mode. with unmodulated line widths <2 MHz.
- the specified temperature range is 20° to 30° C
- specified over the 1520 to 1620 nm wavelength range only

Table 7-9. Amplitude Parameters

	High Resolution	Normal Resolution	Wide Resolution
Power Accuracy ^{a b} over full wl range at –15 dBm, with spans < 12 GHz (0.1 nm)	± 5 dB ^c	± 2.75 dB	± 6 dB ^c
Repeatability ^d with spans < 12 GHz (0.1 nm), over 5 minutes	± 10 dB ^e	± 0.75 dB	± 8 dB ^e
Scale Fidelity with spans ≤ 100 pm –10 dBm to –45 dBm	± 1 dB	± 1 dB	—
Polarization Dependence ^c	± 1.5 dB	± 1.5 dB	—
Displayed average noise level ^c RMS detection; 20 pm span; –5 dBm	—	–65 dB	—
Dynamic Range ^{e, f} at 1550 nm	—	≥ 50 dB	—
Spurious Free Dynamic Range ^c	≥ 40 dB	≥ 40 dB	—
Saturation ^c with 0 dB attenuation		–5 dB	
Maximum safe total input power		23 dBm	
Optical Attenuation Range		20 dB in 1 dB steps	
Optical Return Loss ^c		–50 dB	

a. Does not include PDL, scale fidelity, or repeatability.

b. With unmodulated line widths <2 MHz.

c. Characteristic

d. Assumes constant temperature over measurement interval.

e. With a –5 dBm level adjusted for optimum polarization.

f. Applies to any fixed input level.

General Instrument Specifications

Table 7-10. General Instrument Specifications

Dimensions	
With work surface installed	1300 mm H x 700mm W x 1300mm D
Without work surface	1300 mm H x 700mm W x 880mm D
Weight	190 kg (420 lbs)
Temperature Range	+20 °C to +30 °C
Power Requirements^a	
Option 110	
Voltage and Frequency	110 Vac to 120Vac, 50 Hz to 60 Hz
Max. Power Consumption	400 W
Option 220	
Voltage and Frequency	200 Vac to 240 Vac, 50 Hz to 60 Hz
Max. Power Consumption	400 W
Computer Interfacing	
Operating System	MS Windows 2000
Remote Control Compatibility	LAN Interface
Data Export	Spreadsheet and Word Processor Compatible (CSV)
Graphics Export	JPEG, Bitmap
Floppy Disk	3.5 inch 1.44 MB, MS-DOS®
CD-ROM	40 X Maximum Speed
LAN Interface	INTEL 10/100
Graphical User Interface	15" Touch Screen, VGA
Keyboard/Mouse	PS/2
Additional Interface Cards	Digital Acquisition, GPIB

a. Fuse, F2AH 250 volts, IEC fuse (Agilent part number 2110-0710) located on the Agilent E9393A coherent receiver.

Regulatory Information

- This product complies with 21 CFR 1040.10 and 1040.11.
- This product has been designed and tested in accordance with the standards listed on the Manufacturer's Declaration of Conformity, and has been supplied in a safe condition. The documentation contains information and warnings that must be followed by the user to ensure safe operation and to maintain the product in a safe condition.
- Compliance with Canadian EMC Requirements

This ISM device complies with Canadian ICES-001.

Cet appareil ISM est conforme a la norme NMB du Canada.

Notice for Germany: Noise Declaration

Acoustic Noise Emission	Geraeuschemission
LpA < 70 dB	LpA < 70 dB
Operator position	am Arbeitsplatz
Normal position	normaler Betrieb
per ISO 7779	nach DIN 45635 t.19

Declaration of Conformity

Declaration of Conformity

DECLARATION OF CONFORMITY

According to ISO/IEC Guide 22 and CEN/GENELEC EN 45014

Manufacturer's Name:	Agilent Technologies, Inc.
Manufacturer's Address:	1400 Fountaingrove Parkway Santa Rosa, CA 95403-1799 USA
Declares that the product:	
Product Name:	High Resolution Spectrometer
Model Number:	83453A
Product Options:	This declaration covers all options of the above product.
Is in conformity with:	
Safety:	IEC 61010-1:1990 +A1:1992+A2:1995 / EN 61010-1:1994+A2:1995 CAN/CSA-C22.2 No. 1010.1-92 IEC 60825-1:1998 21CFR 1040.10 & 1040.11
EMC:	IEC 61326-1:1997+A1:1998 / EN 61326-1:1997+A1:1998 CISPR 11:1990/EN 55011:1991 Group 1, Class A IEC 61000-4-2:1995+A1:1998 / EN 61000-4-2:1995, 4 kV CD, 8 kV AD IEC 61000-4-3:1995 / EN 61000-4-3:1995, 3 V/m, 80-1000 MHz IEC 61000-4-4:1995 / EN 61000-4-4:1995, 0.5 kV sig. lines, 1 kV pow. lines IEC 61000-4-5:1995 / EN 61000-4-5:1995, 0.5 kV I-I, 1 kV I-e IEC 61000-4-6:1996 / EN 61000-4-6:1996, 3V 80% AM, power line IEC 61000-4-11:1994 / EN 61000-4-11:1994, 100 %, 20 ms
Supplementary Information:	
	The product herewith complies with the requirements of the Low Voltage Directive 73/23/EEC and the EMC Directive 89/336/EEC and carries the CE-marking accordingly.
	
Santa Rosa, CA, USA	30 January 2002
	Greg Pfeiffer/Quality Engineering Manager
For further information, please contact your local Agilent Technologies sales office, agent or distributor.	

Numerics

83453A
 overview, 2-2

A

activate
 markers, 4-28
 zoom, 4-28
 Agilent offices, 6-28
 amplitude
 repeatability, 7-4
 scale/attenuation settings, 4-13
 specifications, 7-7
 zoom, 4-26
 angled connectors, 7-5
 auto measure, 4-39, 4-50
 auto measure setup, 4-37
 auto scale, 4-25

B

bandwidth markers, 4-18

C

cabling configuration, 1-11
 care of fiber optics, 1-iii, 1-14
 characteristics, instrument, 7-3
 cleaning
 accessories for connectors, 6-23
 adapters, 6-25
 connectors, 6-23
 fiber-optic connections, 6-16, 6-24
 non-lensed connectors, 6-24
 collecting data, 4-30
 connector care, 6-16
 connectors
 accessories, 6-23
 cleaning, 6-23
 continuous sweep, 4-40
 cotton swabs, 6-23
 customer support assistance, 6-27

D

data logging, 4-25, 4-30, 4-33
 db/div, 4-13

declaration of conformity, 7-10
 default settings, 4-38
 definition of specifications, 7-3
 delta marker, 4-17
 detection, peak, 3-7
 detector choices, 4-14
 displaying
 errors, 4-24
 ITU grid, 4-35
 Lorentzian curve, 4-21
 measurement data, 4-25
 measurement results, 4-52
 messages, 4-36
 dust caps, 6-23

E

error messages, viewing, 4-24, 4-36
 example programs, 5-2
 excursion, peak or pit, 4-34

F

FDA laser safety, 1-13
 fiber optics
 care of, 1-iii, 1-14
 cleaning connections, 6-16
 File menu, 4-3
 finding signals, 4-39, 4-50
 fit to window, 4-25
 foam swabs, 6-23
 frequency
 repeatability, 7-3
 zoom, 4-27
 frequency specifications, 7-6
 frequency units, 4-12
 function descriptions, 4-2

G

Gaussian measurement, 4-19
 grid spacing, 4-35

H

high resolution, 3-8, 3-15, 4-48
 HRS overview, 2-2

Index

I

- input connector, 1-iii, 6-16
- installation, 1-2
- instrument
 - characteristics, 7-3
 - preset, 4-38
 - returning for service, 6-26
 - specifications, 7-3
- ITU grid, 3-23, 4-35

K

- key descriptions, 4-2

L

- laser
 - classifications, 1-13
 - safety, 1-13
 - warning, 1-13
- laser linewidth, 3-18
- laser measurements, 3-13
- line-power
 - specifications, 1-5
- linewidth measurement, 3-18, 4-19
- locating signals, 4-39, 4-50
- Lorentzian measurement, 4-19

M

- marker
 - bandwidth, 4-18
 - behavior settings, 4-33
 - delta, 4-17
 - normal, 4-16
 - peak, pit, 4-18
 - search, 4-18
- marker information panel, 4-16
- mean wavelength, 3-26
- measurement results, 4-52
- measuring signals, 4-39, 4-50
- measuring spectral width, 4-18
- message history, 4-24
- modulated measurements, 3-23
- monitor assembly, 1-6
- monitoring signals, 4-25
- multiple traces, 4-24

N

- noise declaration, 7-9
- noise suppression, 3-10
- noise suppression, auto measure setting, 4-37
- noise suppression, reducing noise levels, 4-41
- normal marker, 4-16
- normal resolution, 3-8, 4-48

O

- object select, 4-28
- optimizing signal to noise, 4-41

P

- pan zoom, 4-28
- peak
 - detection, 4-14
 - detection measurements, 3-13
 - excursion, 4-34
 - marker, 4-18
- peak detection, 3-7
- performance verification, 1-14
- phone numbers, customer support, 6-27
- pit excursion, 4-34
- pit marker, 4-18
- polarization dependence, 7-4
- preset states, 4-38
- printing data, 4-8
- printing options, 4-9
- programming, 5-2

R

- rack size, 1-3
- recalling instrument states, 4-7, 4-32
- reference level, 4-13
- regulatory information, 7-9
- remote control, 5-2
- repeat sweeps, 4-40
- resetting the instrument, 4-38
- resolution, 3-8, 4-48
- returning for service, 6-26
- RMS detection, 4-14
 - detection, RMS, 3-6

S

safety considerations, 1-13
 safety information, 1-iii
 sales and service offices, 6-28
 saving
 instrument states, 4-4, 4-32
 screen images, 4-6
 traces, 4-4
 scale fidelity, 7-4
 selecting markers, 4-16
 service
 returning for, 6-26
 sales and service offices, 6-28
 setup panels
 amplitude, 4-13
 frequency/wavelength, 4-11
 markers, 4-16
 measurement, 4-19
 show messages, 4-24
 signal to noise optimization, 4-41
 single sweep, 4-40
 SMSR measurements, 3-21
 software overview, 2-4
 span settings, 4-11
 specifications, 7-5, 7-7
 amplitude, 7-4
 definition of terms, 7-3
 frequency, 7-3
 general, 7-8
 operating, 1-5
 wavelength, 7-6
 spectral mean measurement, 4-19
 spurious responses, 3-12
 stability, 7-4
 start frequency, 4-11
 state settings, 4-32
 status messages, viewing, 4-24, 4-36
 stop frequency, 4-11
 stop sweep, 4-40
 storing a trace, 4-24
 swabs, 6-23
 sweep functions, 4-40
 sweep rate, 3-9
 system
 diagram, 1-11
 installation, 1-2
 overview, 2-2

 preset, 4-38
 rack, 1-3
 settings, 4-29
 verification, 1-14
 system, spurious responses, 3-12

T

telephone numbers, customer support, 6-27
 tool bar functions, 4-43
 trace comparison, 4-24
 transmitter measurements, 3-23
 tuning repeatability, 7-3
 turning markers on, 4-16, 4-28

U

UI overview, 2-4
 undo last zoom, 4-28

V

verifying the system, 1-14
 View menu, 4-10
 viewing
 messages, 4-36

W

wavelength
 repeatability, 7-3
 specifications, 7-6
 units, 4-12
 zoom, 4-27
 wavelength lambda zero, TLS settling, 4-41
 wide resolution, 3-8, 4-48

X

x-axis, wavelength or frequency, 4-12

Y

Ymax settings, 4-13

Z

zoom functions, 4-26

Index

zoom out, 4-27